



Moss Miata

Miata Cutout NC

It is easier to color your Miata before you cut it out. Felt tip markers or color pencils work great.

Carefully cut out the car with an X-Acto knife or scissors.

After cutting out car, fold down tabs, then roll over front and rear body panels, gluing or taping tabs inside to hold body curvature.

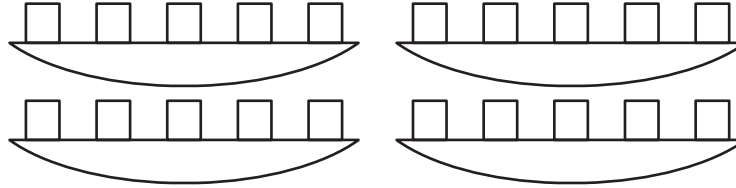

FENDER FLARES

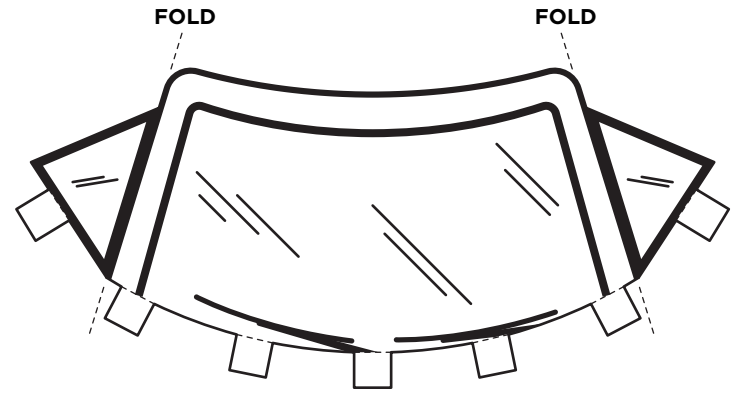

WINDSHIELD

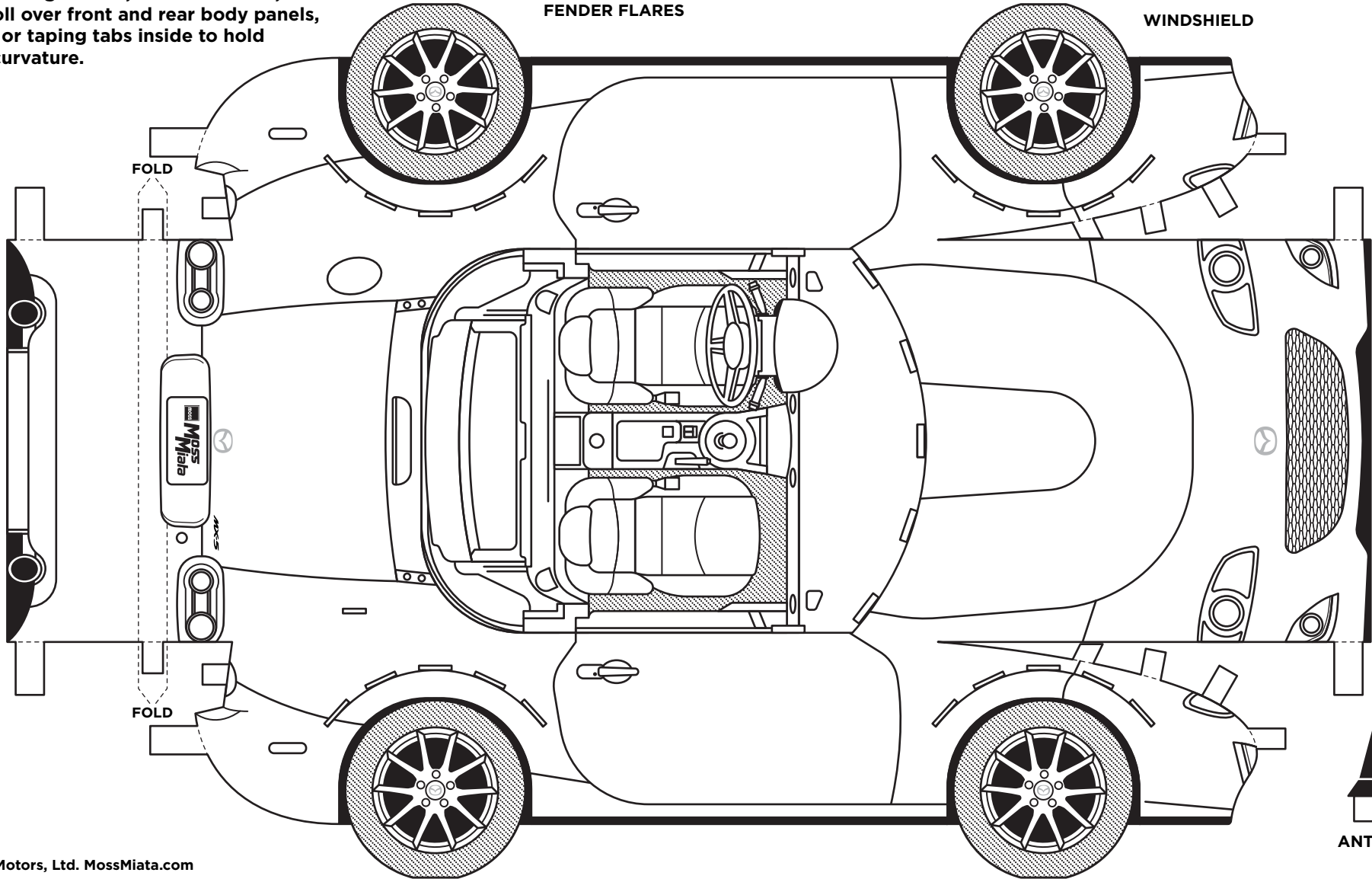

FOLD

FOLD

Tip: Tape completed model to cardboard base. (Black or dark gray looks good.)

Locate windshield in slots on cowl, giving it a slight curvature to make it stand up.



ANTENNA