



MG Midget & Austin-Healey Sprite Alternator Conversion Installation Instructions Sprite/Midget '61-71, Morris Minor

PART #130-068

440 Rutherford St. Goleta, CA 93117
1-800-667-7872 • FAX 805-692-2525 • www.mossmotors.com

Tools required:

- Medium flat blade screwdriver
- Medium phillips screwdriver
- 1/2" wrench, 7/16" wrench, 5/16" wrench
- 9/16" socket, 1/2" socket
- Dead-blow hammer
- Air impact gun
- 22mm socket
- Pry bar
- Wire cutters, wire crimpers
- Pliers
- Voltmeter

Note: The vehicle must be converted to negative ground before the alternator can be installed. These instructions will outline this polarity conversion as a part of the alternator conversion.

If your vehicle is Negative Ground, move on to "Alternator Installation"

Vehicle Preparation: Positive Ground to Negative Ground Conversion

1. Disconnect the battery using a 1/2" wrench.
2. Disconnect the Brown/Green and Brown/Yellow wires from the Generator. If the generator uses ring type connectors use a 5/16" and a 7/16" wrench.
3. Reverse the positions of the two wires on the ignition coil. Note: If the vehicle uses an electronic ignition it will have to be replaced with a negative ground electronic ignition. We recommend Moss Motors # 222-405.
4. If an ammeter or voltmeter has been fitted the position of these wires will need to be reversed.

5. If the fuel pump is solid state it will have to be replaced. We recommend Moss Motors #377-285.
6. If the vehicle uses a mechanical tachometer move on to the next step. If the vehicle uses an electronic tachometer it will need to be converted. To convert the tachometer, John Twist offers the following advice:

Two changes are necessary to completely convert your early positive ground electric tach:

- a.) The wires must be reversed at the "white wire loop" at the back of the unit, and b.) the power and earth connections must be reversed inside the case.
- a.) The wire in the "white wire loop" comes from the key switch and travels to the hot side of the coil. Referring to the illustration below, select one of the wires and tag it with two pieces of tape for identification. Then, cut the wire between the pieces of tape, and cut the other wire to the same length. Reverse the connections (now there is one piece of tape on each wire) and solder them (remember, this is the power lead for the coil and is unfused). Tape up the connections carefully. When later replacing the plastic block on the back of the tach, ensure that the metal band around the block is carefully positioned. This is a necessary part of the electromagnetic pickup.
- b.) To reverse the power wire and earth wire inside the unit, it is necessary to remove the chrome ring, the glass face and the glare shroud. The chrome ring is usually removed with great difficulty by prying the tabs with a small screwdriver, then rotating until the tabs can fit through the slots in the case. Remove the two screws on the back of the unit that hold the internals to the case (not

Installation Instructions

the two whose heads fit in holes in the case), and allow those internals to drop carefully into your hand. Don't bend the needle! The spade terminal is the power connection, just next to this is the earth connection. A resistor is soldered to one of these connections, and a green wire to the other. Unsolder the ends of the green wire and the resistor from their current positions. Re-solder the green wire to where the resistor was connected, and the resistor to where the green wire was connected. Reassemble the unit after cleaning the glass.

Illustration 6

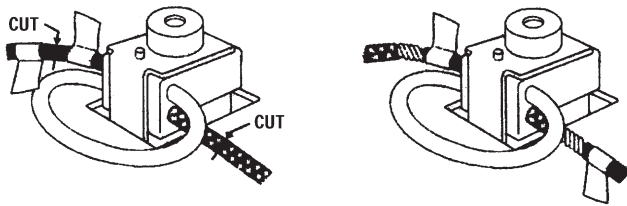

7. Swap the connectors on the battery cables using a 7/16" wrench. Refit the battery so the positive cable is attached to the positive (+) side of the battery. Leave the negative (-) ground cable disconnected until the installation is complete.

Alternator Installation

1. Disconnect the battery using a 1/2" wrench.
2. Disconnect the Brown/Green and Brown/Yellow wires from the Generator. If the generator uses ring type connectors use a 5/16" and a 7/16" wrench.
3. Loosen and remove the nut and lock washer on the pillar block using a 9/16" socket to allow the generator to rotate down and remove the drive belt. (Illustration 2)

Remove the adjustment link from the generator using a 1/2" socket.

Illustration 2

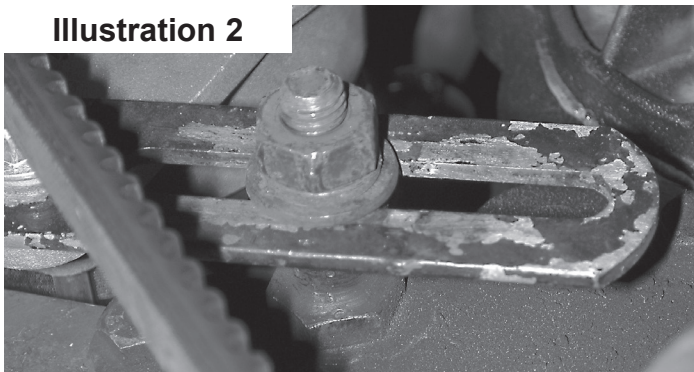

4. Remove the pivot bolts from the water pump ear and the rear mounting bracket using a 1/2" wrench and 1/2" socket.
5. Remove the rear bracket from the block using a 1/2" socket and replace with the new bracket supplied in the kit (Moss part number 130-115) using the same hardware. Do not tighten down the bracket yet.

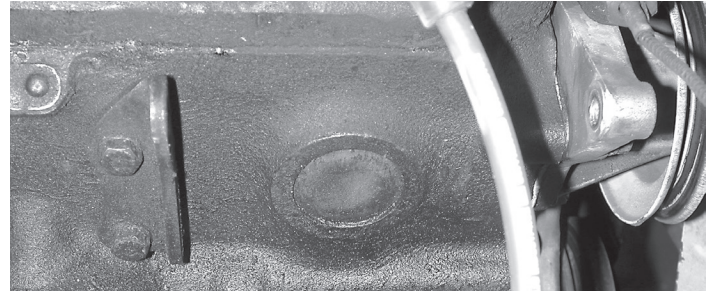
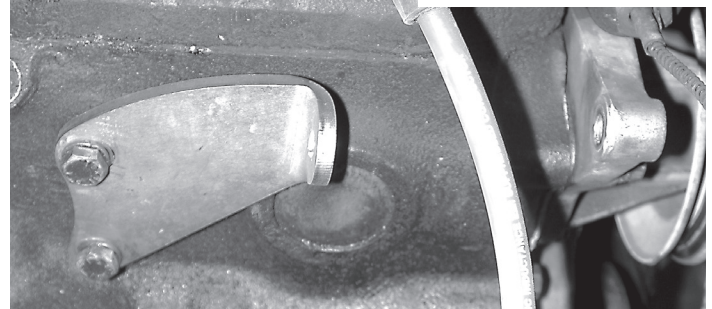

Illustration 5



6. Fit the alternator with the fan and pulley supplied in the kit. It may help to seat the pulley against the fan by tapping the outer edges evenly with a dead-blow hammer. The woodruff key has a tendency to come out during this process. Apply pressure to the key with a flat blade screw driver to keep it in place while tapping the pulley on. Make sure that the fan blades point toward the alternator. Wrap a shop rag around the fan and hold it firmly, but in a safe manner so that it can be released without damage to the hand or fingers. Tighten the nut with two brief (1 sec. max.) trigger pulls on an air impact gun using a 22mm socket. Check that the fan is not loose and repeat the tightening of the nut if necessary. Attach the adjustment link from the generator to the alternator respective to its original position using the M8x1.25x20 bolt and lock washer provided. Do not tighten this bolt yet.
7. Fit the alternator to the engine by first sliding the long slot in the adjustment link over the threaded stud on the pillar block. Line up the front-most mounting ear with the water pump mounting ear and insert the original bolt with one of the flat washers provided. Line up the rearmost mounting ear with the new alternator bracket and insert the 5/16-24 bolt provided. Return the pillar block nut and lock washer to the pillar block. Return the nut and washer to the front mounting bolt

with the added flat washer between the backside of the water pump mounting ear and the lock washer. Return the nut and lock washer from the original rear mounting bolt to the new mounting bolt. Leave the mounting bolts snugly tightened. Make sure that the alternator is at full droop. (See *Illustration 7*)

Illustration 7

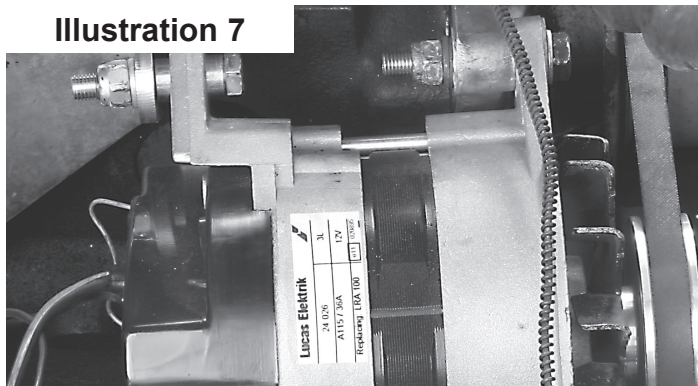

If the wires removed from the generator are fitted with the ring type connectors then the female spade connectors will have to be installed. To do so, remove the ring type connectors with wire cutters and strip 1/4" of insulation off of each wire. Attach one of the two non-covered female spade connectors to the Brown/Yellow wire and a small red spade connector to the Brown/Green wire using wire crimpers. Use a 1" section of the heat shrink provided to cover the larger spade connector.

- Fit the new belt by first locating the crank pulley with the bottom of the belt and then wrapping it around the water pump pulley and finally walking the belt onto the alternator pulley. Tighten the belt using a shop towel and a pry bar wedged in between the alternator and the block. Tighten the pillar block nut to fix the adjustment link. Then tighten the bolt attaching the link to the alternator and the front mounting bolt. Next tighten the rear alternator mounting bolt and then the bracket mounting bolts. The order in which these bolts are tightened is beneficial to the fitment of the new mounting bracket. Check that the belt deflects 3/16"-1/4" at the center of the belt between the water pump pulley and the alternator pulley and adjust as needed.

Illustration 8

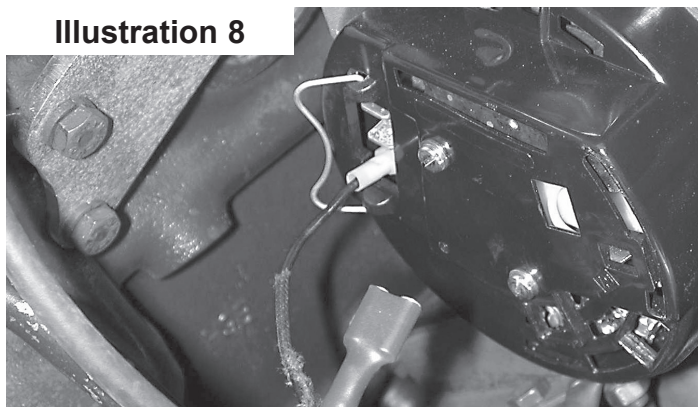

- The first illustration below shows a stock negative (-) ground vehicle's wiring diagram with the generator still intact. Remove all the wires from the control box as show in the second illustration.

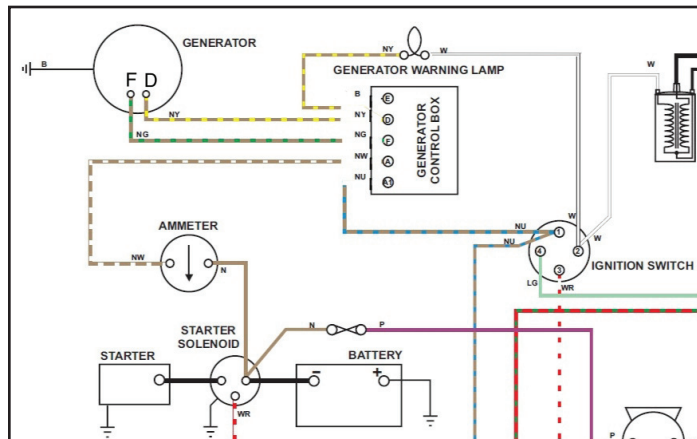
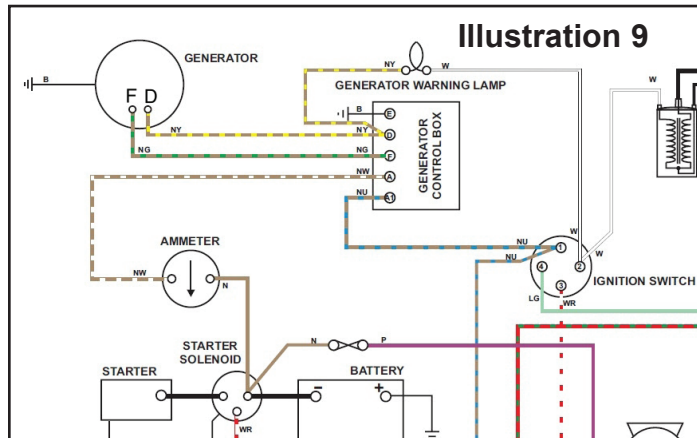

- Plug the wires into your alternator as shown.

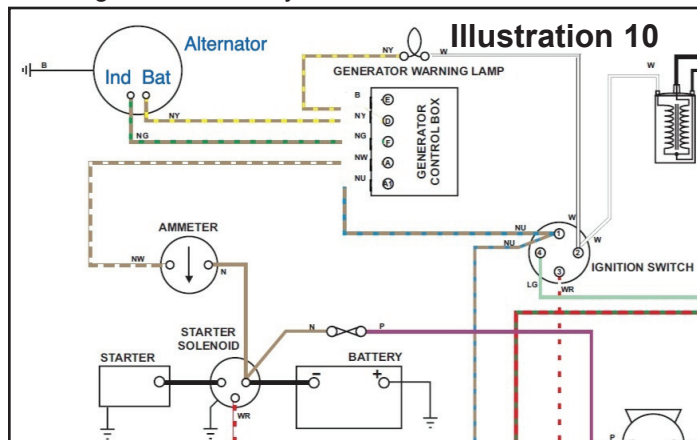

Installation Instructions

11. Complete the wiring on your vehicle using the following diagram. Make sure to insulate the connections. You may remove the regulator (generator control box), it is no longer needed.

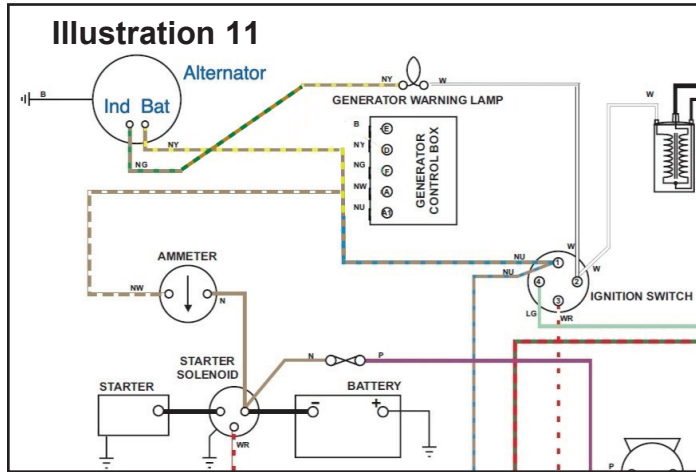

12. Turn the key to the on position and do not start it. Check all of the modified areas and insure that there is no sparking or smoke. Now start the car bring to steady idle. Attach a voltmeter to the battery terminals and verify that the reading is greater than 13 volts. Rev the car up and verify that the voltage reading increases with RPM.
13. Install the negative (ground) battery cable to the negative (-) terminal of the battery.
14. Enjoy your new Moss alternator conversion kit! See MossMotors.com for all your parts and accessories.