

1 **Supplemental Information & Instructions**  
2 **for**  
3 **163-700 Distributor Plate w/ Points & Coil Terminal**  
4 **Original Distributors fitted to MG TC, TD, TF**

Many T-series cars have distributors have been torn down and rebuilt so many times they are no longer functional. The post the points pivot on comes loose or breaks off. The threaded holes have been used and abused – often without regard to the original 2BA and 4BA threads- that the correct screws will no longer fit or stay put. The insulated terminal for the coil wire has been lost or modified. If you have a plate with the condenser soldered in place, there is no easy way to replace it. Fitting a replacement plate with new condenser and points makes sense.

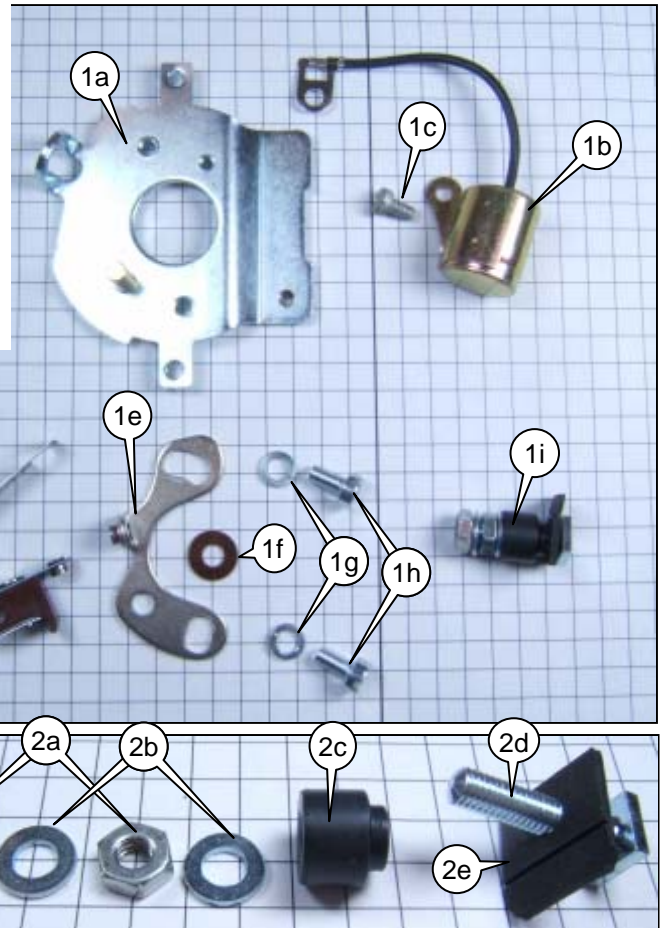

- 18 The 163-700 is a kit consisting of the following  
19 components:  
20 1a 152-900 Plate, distributor  
21 1b 163-900 Condenser  
22 1c 323-021 Screw, 4BA, for condenser  
23 152-200 Ignition Points  
24 *Consisting of ...*  
25 1d Moving contact  
26 1e Fixed contact  
27 1f Insulating washer  
28 1g 324-010 Lock washer (2)  
29 1h 323-246 Screw, 2BA (for fixed contact)  
30  
31 1i 152-901 Terminal for coil wire  
32 *Consisting of ...*  
33 2a Hex nut, 3/16-32 (2)  
34 2b Flat washer (2)  
35 2c Insulating spacer  
36 2d Terminal Stud, 3/16-32  
37 2e Insulating pad, scored for bend  
38

39 *For those of you who are familiar with the plate assembly, putting these components together will not be a*  
40 *challenge. For those of you who are not quite so familiar, we have some assembly tips.*

41 **Assembly Tips**

42 Mount the condenser to the plate with the 4BA screw (3a)  
43 provided.

44  
45 Modern condensers come with a “flag terminal” that is a little too  
46 small for the 3/16” stud (2d above). The hole will need  
47 to be enlarged. A tapered reamer (4a) will make a  
48 quick job of it. It is best to hold the terminal with a pair  
49 of needle nose pliers as you enlarge the hole.

50  
51 Once the “flag” slides all the way to the  
52 square head on the stud as shown (5a),  
53 the hole is large enough.  
54  
55

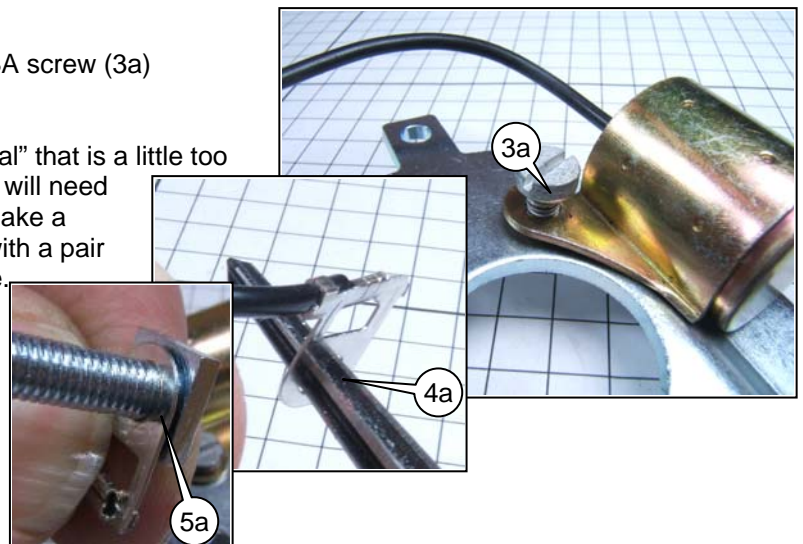

56 **Assembly Tips, continued**

57 The stud (2d above) is isolated from the breaker plate by a combination of a  
58 square insulating washer made from waterproof panel board (6a) and a  
59 black cylindrical insulating spacer (8a).

60  
61 The square washer comes with a groove in it to  
62 make it easy to fold (6b). The horizontal section of  
63 the square washer prevents the head of the  
64 stud (7a) from touching the plate itself.

65  
66 The black cylindrical insulator (8a) slides onto  
67 the stud with the necked-down section next to  
68 the square head on the stud. At this point, this  
69 insulator (9b) is secured with one nut and flat  
70 washer (9c).

71  
72 *Note that the flag terminal (9a) on the condenser  
73 wire must be trapped between the square head  
74 of the stud and the square insulating washer.*

75  
76 There are a variety of condensers available that  
77 will work in this application. For instance, we can  
78 supply 154-000 which has the mounting tab  
79 secured to the bottom of the "can". We provide a  
80 second hole for the 4BA screw (9d) which can  
81 be used to secure condensers like the 154-000.

82  
83  
84  
85  
86  
87  
88  
89  
90 The ignition points have a fixed base that is  
91 secured to the breaker plate using two 2BA  
92 screws with lock washers (10a).

93  
94 The fiber insulating washer (10b) drops down  
95 over the brass post.

96  
97  
98  
99  
100  
101  
102  
103  
104  
105  
106  
107  
108  
109  
110

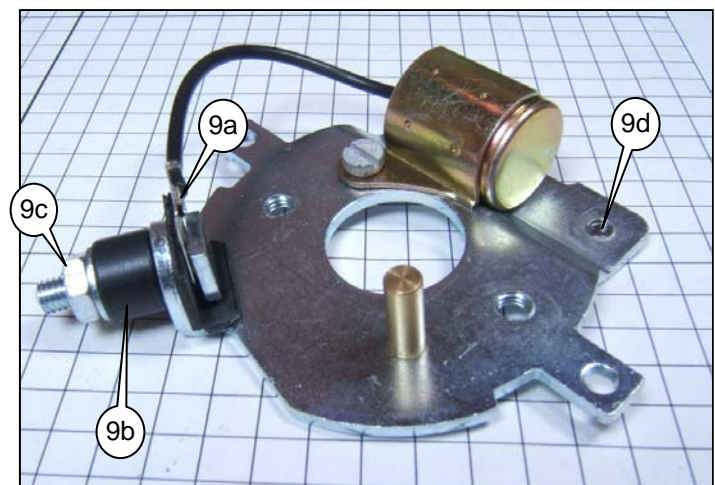
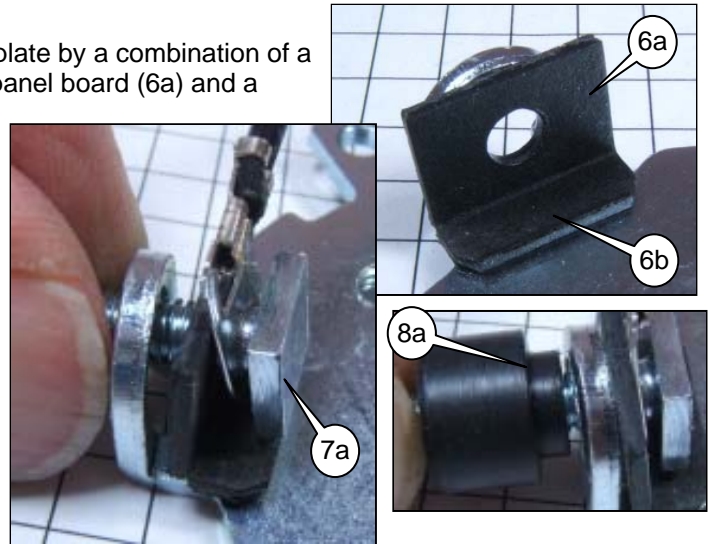

111 **Assembly Tips, continued**

112 The movable side of the ignition points (11a) have a stiff  
113 spring steel "blade" (11b) that presses the rubbing block  
114 against the cam lobes on the distributor shaft. It also  
115 serves as the electrical conductor between the points  
116 and the coil wire, which will be attached to the terminal  
117 stud (11d).

118  
119  
120  
121  
122  
123  
124  
125  
126  
127  
128  
129  
130



131 The replacement plate differs in several ways from an  
132 early original plate (12a) but it drops into the original  
133 distributor body (13a) and is secured with the original two  
134 4BA screws. (If you need to replace these screws, order  
135 323-021; they are not supplied with the distributor plate.)

136  
137 Please consult your workshop manual for information on  
138 setting the points and distributor maintenance.

139  
140  
141  
142  
143  
144

*We strongly suggest that you thoroughly inspect the distributor before installing the new plate. There is no point in fitting the new plate if the distributor shaft bushings are worn or the advance weights are frozen.*

145  
146  
147  
148  
149  
150  
151  
152  
153

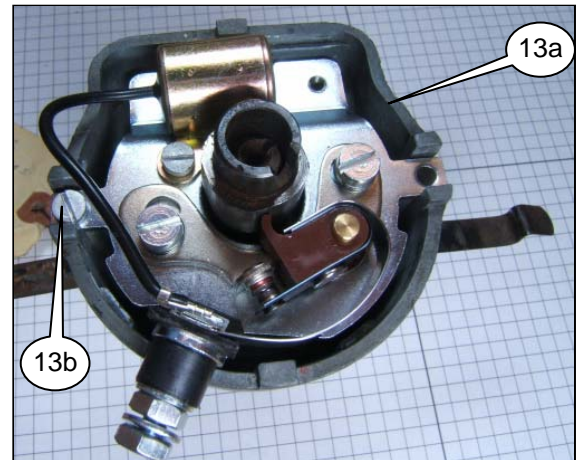
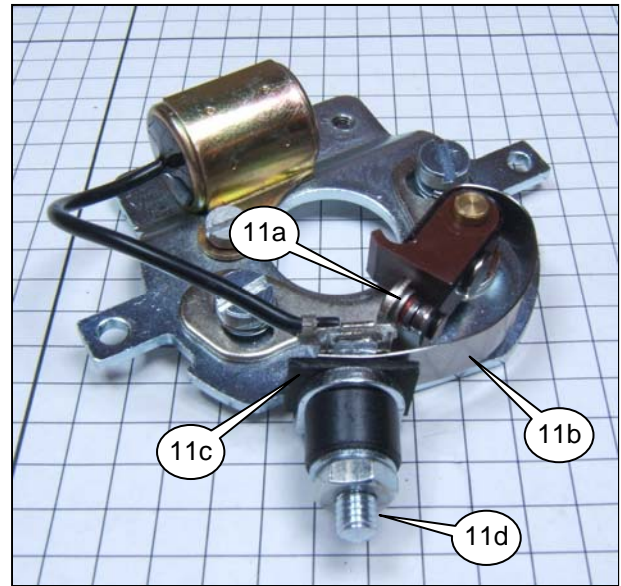

154  
155  
156

*Although every effort has been made to ensure the accuracy and clarity of this information, any suggestions that you may have that will improve the information (especially detailed installation notes) are welcome.*

*Please use the simple email form on the "Contact Us" page on the Moss website:*

<http://www.mossmotors.com/AboutMoss/ContactUs.aspx>

*If you prefer, you may call our Technical Services Department at 805-681-3411. So many people call us for help that we are often not able to answer the calls as fast as we'd like, and you may be asked to leave a message. We apologize in advance for the inconvenience. We will get back to you within 2 business days.*



**Moss Motors, Ltd.**

440 Rutherford Street, Goleta, California 93117  
In the US & Canada Toll Free (800) 667-7872 FAX (805) 692-2510 (805) 681-3400

**Moss Europe Ltd.**

Hampton Farm Industrial Estate, Hampton Road West, Hanworth Middlesex, TW13 6DB  
In the UK: 020-8867-2020 FAX:- 020-8867-2030