



TOURIST TROPHY®

# MGA Luggage Rack

## Installation Instructions

### MGA

PART# 244-703

#### Tools required:

- 13mm wrench
- 13mm socket
- Ratchet
- Masking tape
- Felt tipped pen
- Tape measure
- Medium strength thread locker
- 13mm Socket or wrench
- Center Punch
- Pilot hole drill bit
- 11/32" drill bit
- Drill
- Razor blade
- 3/8" Gasket punch
- Superglue or weatherstrip adhesive
- 11/32 drill bit
- Straightedge or ruler
- Small round file
- Two trunk props or assistant

*Actual parts may vary from figures*

#### Installation

**Note:** *If there are preexisting holes in the trunk lid from the installation of another luggage rack, look at the end of the instructions to see if this rack will cover the existing holes.*

**If the rack came out of the box partially assembled, check to ensure it is assembled properly.**

1. Wash and dry the trunk lid. Any dirt, dust or water left on the paint may result in poor tape adhesion and paint damage.
2. Begin assembly of the rack by locating the two mounting straps, two mounting rods, four M8x12 bolts, and four flat washers included with the kit.
3. Assemble the mounting straps and rods one at a time. Use two M8x12 bolts and two flat washers to fasten the ends of the mounting rod to the holes in the ends of the mounting strap. Do not over tighten or use thread locker. Assemble the other rod and strap in the same fashion. Figure 3.

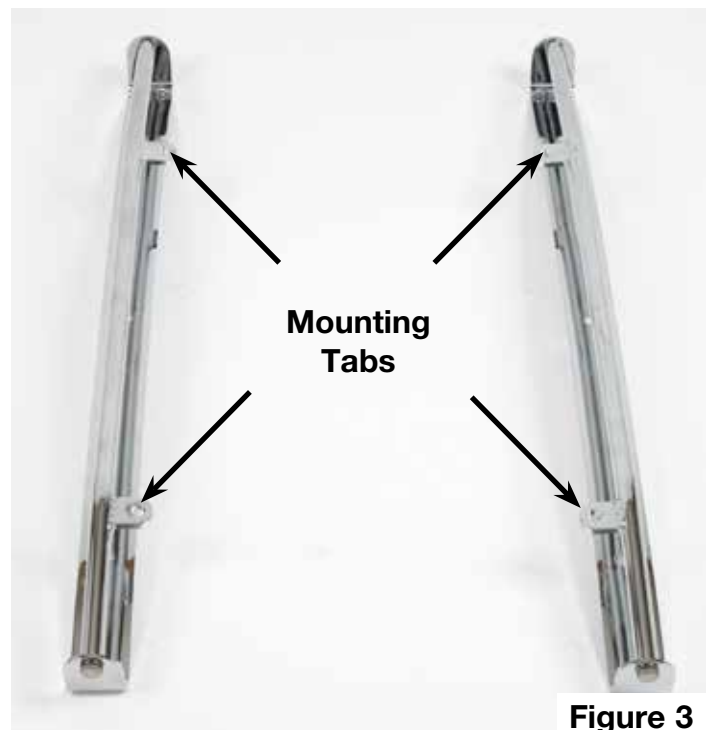

## Installation Instructions

- Determine the correct orientation of the rod and strap assemblies. The front and rear of the mounting rod can be determined by the distance from the end of the rod to the nearest mounting tab. The front end of the assembly has a distance of 7" between it and the tab, while the rear tab is 4" away from the rear end of the rod. Orient the rod and strap assemblies with the rear closest to you, and the mounting tabs pointed toward the center as shown in Figure 4. If holes from a previous rack need to be covered, refer to "Covering Existing Holes" on page 5 for the correct orientation of the rod and strap assemblies.



- Place the luggage rack on the rod and strap assemblies with the luggage support bar at the rear. Line the holes on the bottom of the luggage rack up with the holes in the mounting tabs, and bolt them together using thread locker, four M8x12 bolts and four flat washers. Before fully tightening, use a measuring tape to verify that the rod and strap assemblies run parallel to each other. Figure 5.



- Once the bolts holding the luggage rack together are tightened, measure the distance between the inside edges of both mounts at three different points. The distance measured will be around 19". All measurements should be equal or very close if the mounts are parallel. Once the mounts are parallel, record the measurement to be used later. Figure 6.

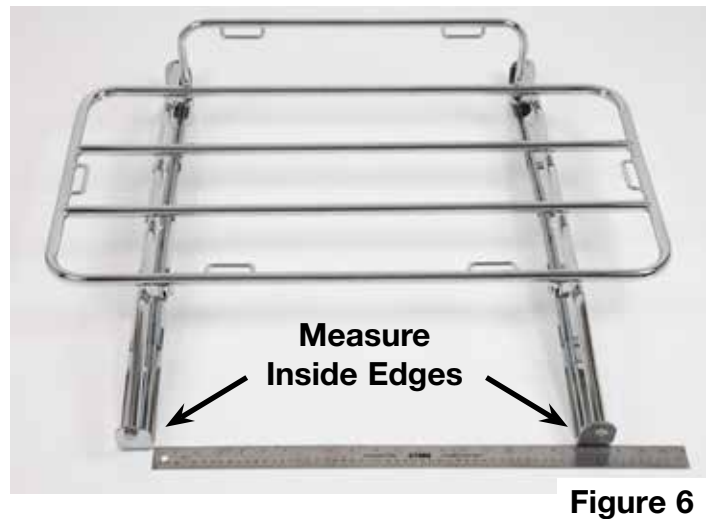

- Place three pieces of masking tape running horizontally from one side of the trunk lid to the other. Place the tape at the top, bottom, and center of the trunk lid where the sides are still flat. The pieces of tape should be 7"-8" away from each other and level. Figure 7.



**Figure 7**

- Find the exact centerline of the trunk using a tape measure. Measure from the left to right side of all three pieces of tape, and mark the center point with a felt tipped pen. Figure 8.



**Figure 8**

- Take half of the distance between the inside edges of the rack measured in step 6, and use masking tape and a felt tipped pen to mark this distance on both the left and right sides of the centerline. These marks indicate the correct placement of both inside edges of the rod and strap assemblies. Figure 9.

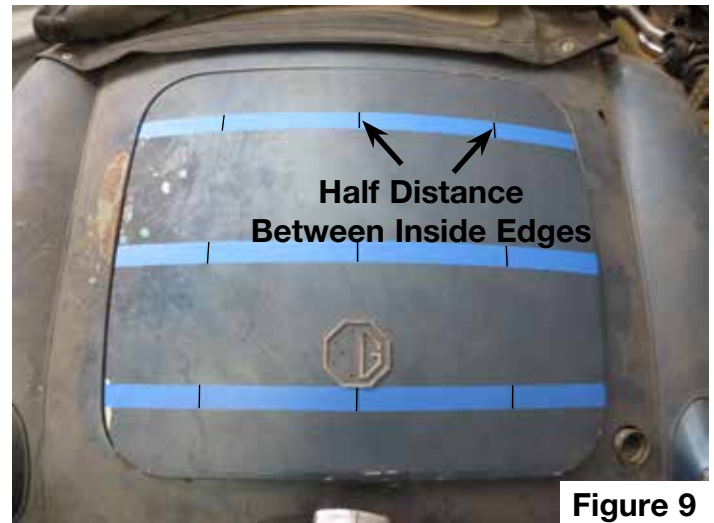

**Figure 9**

- Use two strips of masking tape and lay them down vertically with the inside edges touching the lines made in the last step. To prevent damage to the paint, these strips need to be at least 2" wide. Strips can be added to the outside edge of the first strip if it is too narrow. Figure 10.



**Figure 10**

- Hold the trunk lid in a flat position, and support it in at least two places to prevent flexing.
- Set the luggage rack on the two vertical strips of tape. The inside edges should line up with the marks made in step 8, and the rear of both rod and strap assemblies should line up with the very bottom of the trunk lid. Make any marks on the tape and assemblies to ensure that the individual straps can be put back in the same exact position. Figure 12.

## Installation Instructions

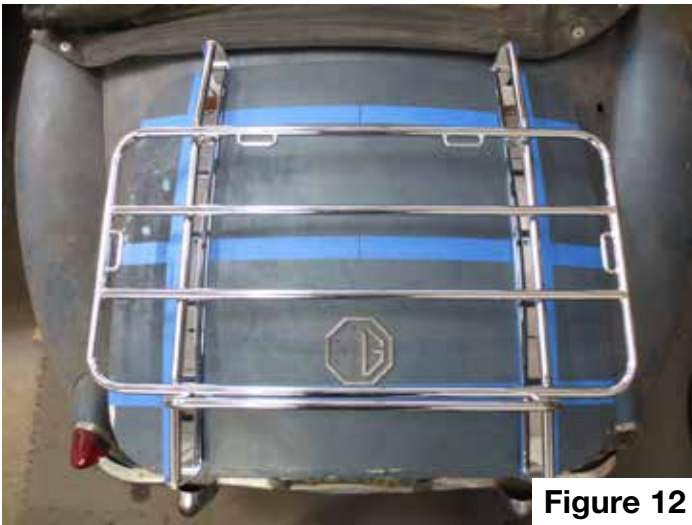

**Figure 12**

13. Take the luggage rack off of the trunk and remove the four M8x12 bolts holding the mounting straps to the rods, and separate them.
14. Place the straps back onto the trunk in the exact same position as before. Use the three lines, the bottom of the trunk lid, and any other marks made to ensure that they are in the same position. Figure 14.

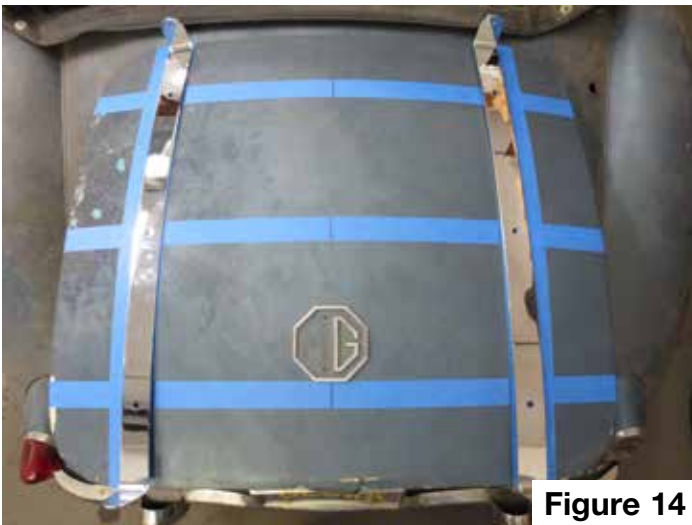

**Figure 14**

15. With one of the mounting straps in position, mark the bottom mounting hole with a felt tipped pen. Because the mounting strap will need to flex to fit the trunk lid, each hole will need to be marked and drilled individually.
16. Carefully center punch and drill the bottom hole of the first mount. Drill a pilot hole, and then follow up with an 11/32" drill bit. Clean and deburr the hole with a small file once finished. The trunk lid is thin aluminum, so work carefully to prevent damage.
17. Find an M8x15 bolt, flat washer, fender washer, and nut. Loosely bolt the rod and strap assembly to the trunk lid using the fender washer and nut on the underside. Loosely tighten the nut and bolt with a 13mm wrench and socket.
18. Repeat the process for the middle and top mounting holes. Be sure that all of the lines still match up and that the mounting strap is still in the correct place.
19. Do the same for the other assembly, but check that the luggage rack will still fit before drilling each individual hole. If there are any issues with alignment the holes can be slightly enlarged with a file.
20. Bolt the luggage rack to the mounting strap using thread locker.
21. Remove the entire luggage rack from the trunk lid.
22. Use a tape measure, straight edge, and razor blade to cut the provided rubber strip to the length of each rod and strap assembly. Be sure to account for the bend in both rod and strap assemblies when measuring. It is also recommended to leave the rubber slightly longer than the mounting strap.
23. Position the rubber strips on the rod and strap assemblies and mark the six bolt holes with a felt tipped pen. Use a punch or razor blade to make a 3/8" hole at all six marks.
24. Apply a thin layer superglue or weather strip adhesive down the center of each rod and strap assembly. Carefully press the rubber strip on the assembly ensuring that holes in the rubber strip line up with the mounting strap.
25. Remove the tape and clean the trunk lid of any residue.
26. Clean the rubber strips where they will make contact with the trunk lid.
27. Open the trunk and position the luggage rack over the mounting holes.
28. With the remaining bolts, washers, and nuts, bolt the luggage rack to the trunk lid. Place six M8x15 bolts and flat washers through the tops of the rod & strap assemblies, trunk lid, and secure them on the backside with six fender washers, nuts, and thread locker. Verify that the luggage rack is still lined up correctly.
29. Close the trunk and verify that the luggage rack is mounted securely to the vehicle.

## Covering Existing Holes

This luggage rack is typically installed with the mounting tabs facing toward the center of the vehicle, this results in the rod and strap assemblies sitting as wide as possible. If holes from a previous more narrow luggage rack need to be covered, the rod and strap assemblies can be swapped side to side so that the tabs face away from the center of the vehicle. Swapping the assemblies will reduce the width of the rod and strap assemblies by nearly four inches. With the assemblies in the normal position, the mounting tabs facing toward the centerline, the mounting holes are  $20 \frac{5}{8}$ " apart, and with the assemblies in the narrow position the mounting holes are  $16 \frac{27}{32}$ " apart.

### Normal (Tabs Pointing Toward Center)

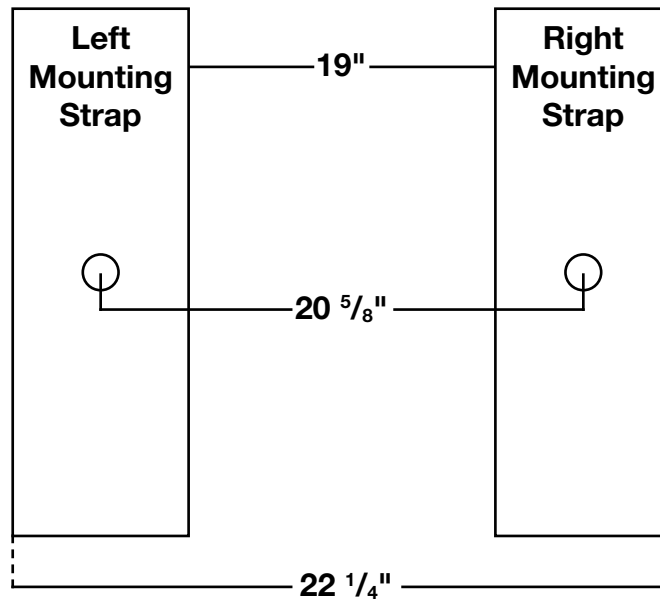

### Narrow (Tabs Pointing Away From Center)

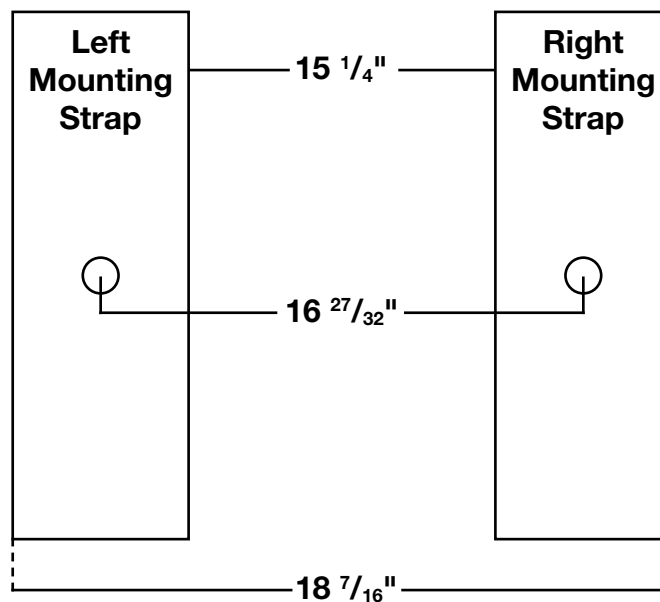

# Installation Instructions

## What's Included

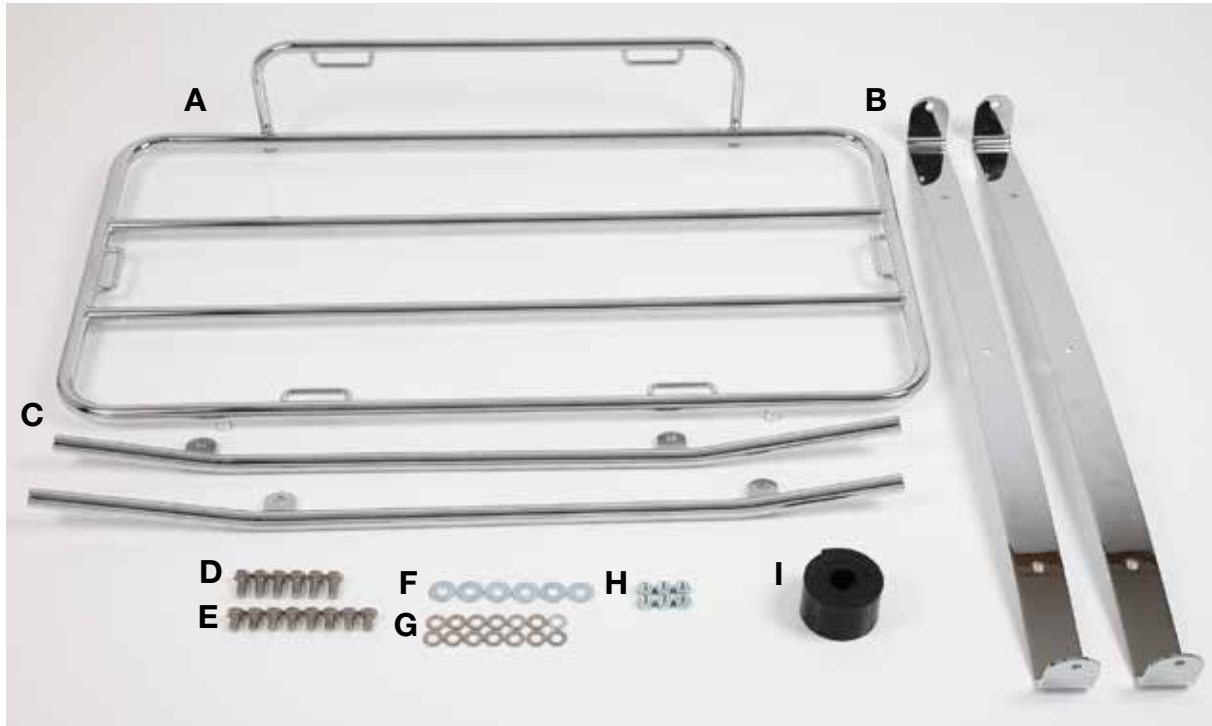

### Contents of the kit #244-703

Note - Specifications and components are subject to change and revision without notice.

Item No.	Description	Quantity
A	Luggage rack	1
B	Mounting strap	2
C	Mounting rod	2
D	M8x1.25x15	6
E	M8x1.25x12	8
F	M8 fender washer	6
G	M8 flat washer	14
H	M8x1.25 Nut	6
I	Rubber strip	1

**Designed and Distributed by Moss Motors, Ltd.**

*For questions or comments please contact:*

**Moss Motors, Ltd.**  
 440 Rutherford Street, Goleta, California 93117  
 In the US & Canada Toll Free (800) 667-7872  
 LOCAL (805) 681-3400 FAX (805) 692-2510



**Moss Europe Ltd.**  
 Hampton Farm Industrial Estate  
 Hampton Road West, Hanworth Middlesex, TW13 6DB  
 In the UK: 020-8867-2020 FAX: 020-8867-2030