

## Supplemental Information & Instructions for MG TD Panel Kits

Part No	Color	Material	Part No	Color	Material
<input type="checkbox"/> 245-280	RED	Leather/Vinyl	<input type="checkbox"/> 245-400	RED	Vinyl
<input type="checkbox"/> 245-290	GREEN	Leather/Vinyl	<input type="checkbox"/> 245-410	GREEN	Vinyl
<input type="checkbox"/> 245-300	BISCUIT	Leather/Vinyl	<input type="checkbox"/> 245-420	BISCUIT	Vinyl
<input type="checkbox"/> 245-310	BLACK	Leather/Vinyl	<input type="checkbox"/> 245-430	BLACK	Vinyl
<input type="checkbox"/> 245-550	TAN	Leather/Vinyl	<input type="checkbox"/> 245-580	TAN	Vinyl
<input type="checkbox"/> 245-552	HONEY TAN	Leather/Vinyl	<input type="checkbox"/> 245-582	HONEY TAN	Vinyl

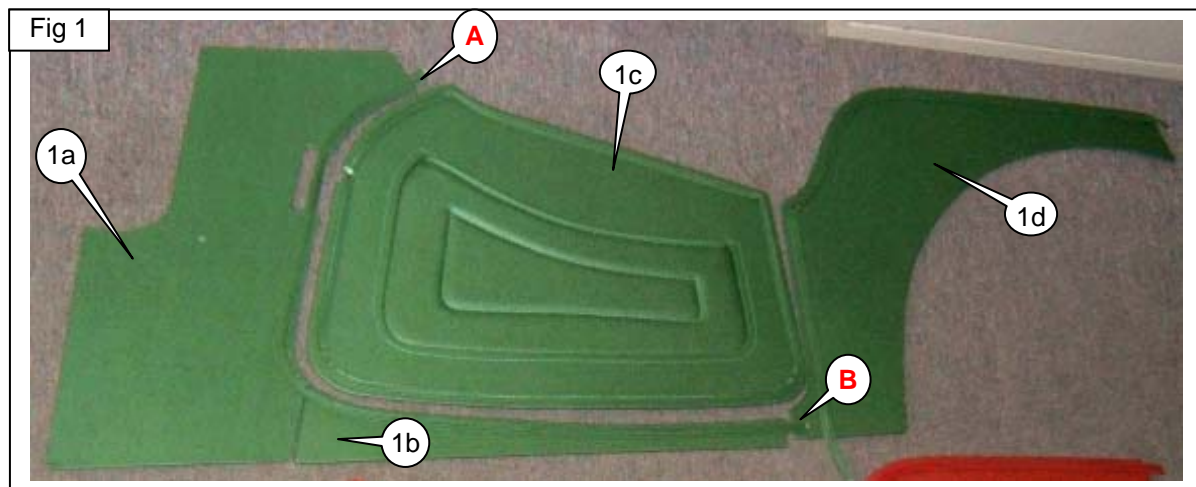

Ref	Qty	Description
1a	1 PAIR, L&R	PANEL, FRONT KICK
1b	1 PAIR, L&R	PANEL, SILL
<i>Note: the sill panel is connected to the front kick panel with a continuous strip of hidem that runs from point A to B.</i>		
1c	1 PAIR, L&R	PANEL, DOOR, with Pocket
1d	1 PAIR, L&R	PANEL, REAR QUARTER
2a	1 EACH	VINYL, BULK, 54" wide
2b	1 PAIR	TABS w/SNAPS
<i>For side curtain compartment lid</i>		
2c	12 FEET	BINDING, BLACK, 3/4"
<i>For the base of the wheel arch covers and inside of side curtain lid.</i>		
2d	1 EACH	PIPING, Leather
<i>For the top edge of the door panels.</i>		
3a	1 PAIR-LR	WHEEL ARCH COVERS
3b	20 FEET	PIPING, VINYL, 9/32
<i>Used between the panels and the body tub.</i>		

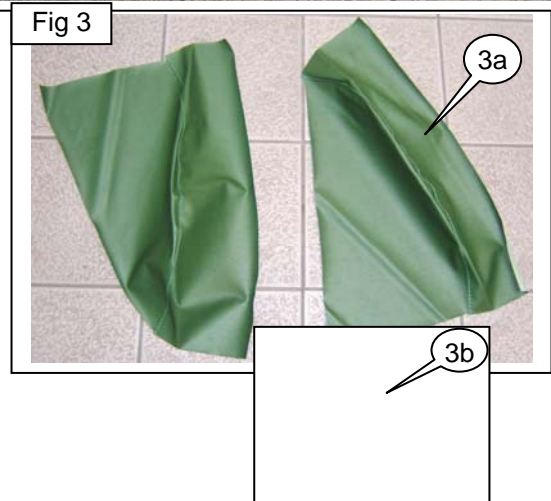
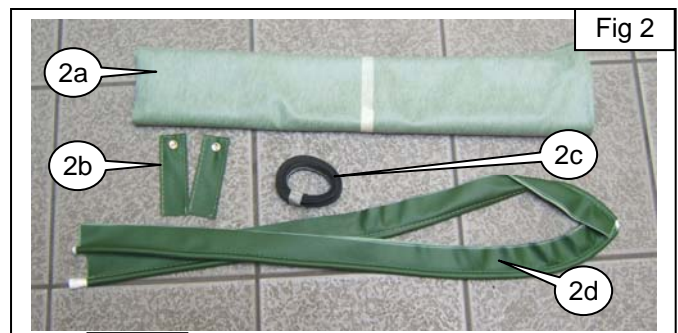

1  
2  
3  
4  
5  
6  
7  
8  
9  
10  
11  
12  
13  
14  
15  
16  
17  
18  
19  
20  
21  
22  
23  
24  
25  
26  
27  
28  
29  
30  
31  
32  
33  
34  
35  
36  
37  
38  
39  
40  
41  
42  
43  
44  
45  
46

47 It is not possible to give exact step-by-step instructions on every detail of a panel kit  
48 installation. It is therefore essential that you study the original upholstery before you  
49 remove it. If that is not possible, ask a friend or fellow club member with a TD if you can  
50 take pictures of their car. If you do not belong to an MG club, we urge you to join. You  
51 can learn more from someone who has installed a panel kit in 20 minutes than we can  
52 explain in 20 pages of text. Some clubs hold tech sessions, and you may find one or  
53 more club members who are willing to help if you make it a club function, especially if  
54 you provide food and drink. When you look at a finished TD, pay particular attention to  
55 the side curtain compartment, top back rail and top tacking strips.

56  
57 The best guide to upholstery installation we are aware of is The Complete MG TD  
58 Restoration Manual by Horst Schach. It is 216 pages, with over 400 black & white  
59 illustrations to go along with the text. The chapters on upholstery are particularly good.  
60 The book is available through the New England MGT Register. The club sells the book  
61 to raise money for the club, and for that reason Moss has never offered the book. The  
62 club can be reached through their website: <http://www.nemgtr.org/>

63  
64 *What follows are some very basic instructions and tips aimed at the professional*  
65 *restorer with experience upholstering other classics, but not so much experience with*  
66 *the MG TD.*

67  
68 Remove seats, dash and miscellaneous hardware and the four gas tank strap retaining  
69 bolts.

70 Dismantle the vinyl covered portions of the side curtain compartment, miscellaneous  
71 vinyl and all tacks.

72 Lay all loose wood parts to be covered on the back side of the bulk vinyl material, but do  
73 not cut until any and all additional requirements are taken into consideration.

74 *When calculating material size requirements, insure that sufficient material is left with*  
75 *which to grab and pull the material into position. Remember the area above the side*  
76 *curtain compartment, and that the glove box lid is covered on both sides and will require*  
77 *two pieces in addition to this allotted for the dash board itself. The flat rear deck*  
78 *area above the rear axle was originally painted black and was not upholstered or*  
79 *carpeted.*

80 The corner tacking pieces for the  
81 convertible top should be covered with  
82 some of the bulk vinyl and installed first.  
83 *These corner pieces were originally*  
84 *upholstered with a flap extending down into*  
85 *the body tub and tacked to the wood just*  
86 *above the wheel arches.*

87 The top of the wheel arches and the top  
88 back rail (through which the gas tank strap  
89 bolts pass) were originally padded with felt.  
90 Reuse it if you can. If the felt is gone or  
91 deteriorated to the point where it cannot be  
92 used, 1/4" foam may be used.

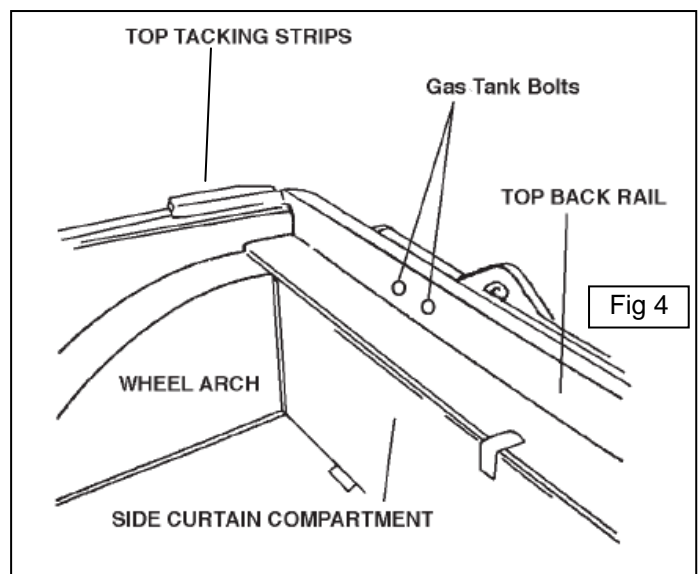

93

94 The top back rail and the long section of the top tacking strip should be covered  
95 together. The screws for the tacking strip should be concealed under the vinyl which  
96 makes for an interesting challenge for the installer. The end of the loose material is  
97 tacked to the underside of the uninstalled tacking strip. After screwing the tacking strip  
98 into position, bring the material up, over and down the front side of the top back rail and  
99 tack it into position in the underside of the rail.

100

101 The gas tank strap bolts (originally painted) may now be reinstalled.

102

103 The wheel arch covers should be installed with contact cement and tacks, as should the  
104 covering for the miscellaneous side curtain compartment panels. The side curtain  
105 compartment pieces may now be re-installed.

106

107 The piping which fits between the dash upholstery panels and the body tub should be  
108 installed in one continuous section extending from the forward tip of the right hand  
109 corner, top tacking strip, clear around to the same spot on the left hand side. For an  
110 authentic installation, do not cut the piping along the bottom edge of the dash, also tuck  
111 the ends of the piping into the tacking strip cover corners. As the piping is being tacked  
112 to the body tub, place the appropriate panel into position and adjust the piping as  
113 necessary to insure that it fits snugly against the edge of the trim panel. A really neat  
114 installation of piping will require patience, but will be well worth the effort.

115

116 The leather door piping was originally stapled to the door panel which works well if short  
117 staples or tacks are available. If not, simply tack the piping to the door frame. The  
118 piping should extend from the top edge of the door hinge to the notch in the door panel  
119 behind the door lock. Piping was not originally fitted to the lower edges of the door  
120 panel.

121

122 Holes for the door locks, side  
123 curtain fixing plates, and  
124 convertible top frame should be  
125 very carefully located and drilled.  
126 Top and side curtains will not fit  
127 properly unless  
128 their respective holes are  
129 accurately located.

130

131 All trim panels may now be  
132 positioned and tacked into place  
133 using 1/4" wire brads.

134

135

136

137

138

139

140

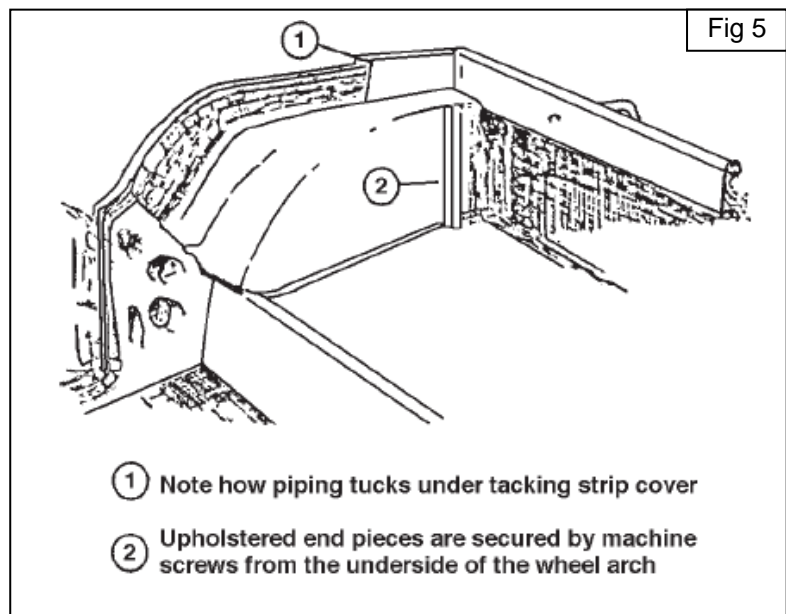

141  
142  
143  
144  
145  
146  
147  
148  
149  
150  
151  
152  
153  
154  
155  
156  
157  
158  
159  
160  
161  
162  
163  
164  
165  
166  
167  
168  
169  
170  
171  
172  
173  
174  
175  
176  
177  
178  
179  
180  
181

*Although every effort has been made to ensure the accuracy and clarity of this information, errors and/or omissions on our part are almost inevitable. Any suggestions that you may have that will improve the information (especially detailed installation notes) are welcome. Please use the simple email form on the "Contact Us" page on the Moss website: <http://www.mossmotors.com/AboutMoss/ContactUs.aspx> If you prefer, you may call our Technical Services Department at 805-681-3411. So many people call us for help that we are often not able to answer the calls as fast as we'd like, and you may be asked to leave a message. We apologize in advance for the inconvenience. We will get back to you within 2 business days.*



**Moss Motors, Ltd.**

440 Rutherford Street, Goleta, California 93117  
In the US & Canada Toll Free (800) 667-7872 FAX (805) 692-2510 (805) 681-3400

**Moss Europe Ltd.**

Hampton Farm Industrial Estate, Hampton Road West, Hanworth Middlesex, TW13 6DB  
In the UK: 020-8867-2020 FAX:- 020-8867-2030  
Instruction Sheet

245-280-245-290\_245-300\_245-310\_245-550\_245-400\_245-410\_245-420\_245-430\_245-580\_980-017  
Originally issued July 2001, revised September 2009