

Supplemental Information & Instructions for 377-258 or AAA1477K Fuel Pump Mounting Kit For MGTD, MGTF TO (E) 31536, and MGA

This kit covers multiple applications. There are parts included in this kit that will not be used in your application because of differences between the vehicles.

Contents of Kit (Refer to Fig 1)

Ref	Item #	Description	Qty
1A	377-200	Bracket, fuel pump mount	1
1B	320-180	Setscrew, 1/4 BSF X 5/8, for pump	2
1C	324-855	Lock Washer, 1/4, for setscrews	2
1D	310-100	Nut, Nyloc, 1/4 UNF, thin	2
1E	280-230	Rubber Pad, for fuel pump bracket	2
1F	324-590	Flat Washer, 1/4 IN, for MGA	2
2F	377-220	Retainer Plate, over rubber pad, for MGT	1
1G	322-247	Bolt, 1/4 UNF X 1, bracket to chassis	2

Fig 1, from MGA factory parts book

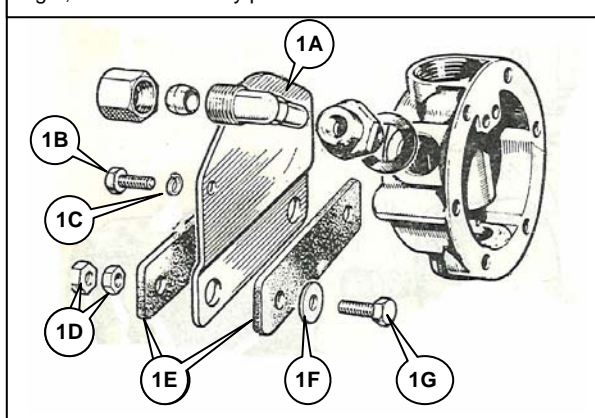

Instructions for MG TD, TF to (E)31536

Since the retainer plate (2F) is raw steel, we suggest that you prep it and paint it black.

1. Secure the fuel pump to the bracket (2A) using the two 1/4 BSF setscrews (2B) and 1/4" lock washers provided.
2. Put one of the rubber pads (2E) on either side of the bracket.
3. Push the 1/4" x 1" bolts (2G) through retainer plate (2F) and through the pads (2E) and the bracket (2A).
4. Hold the assembly up to the bulkhead and line up the bolts (2G) with the holes in the bulkhead. Push the bolts through the hole and hold the assembly in place. Thread the Nyloc nuts onto the bolts from inside the toolbox, and tighten the bolts. *If the holes in the bulkhead are too big, use the 1/4" washers supplied for the MGA under the nuts.*

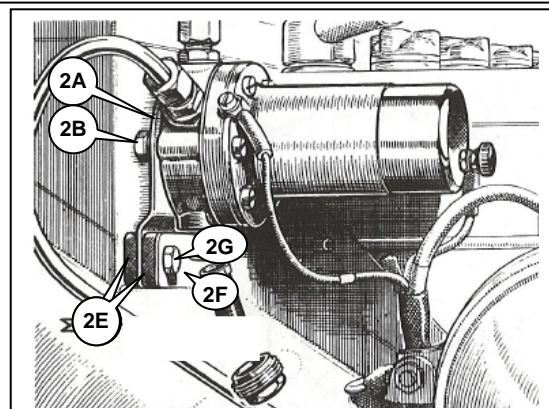

Fig 2, MGTD, TF TO (E) 31536, from w/s manual

Instructions for MGA

The fuel pump in MGAs (& TFs after (E) 31536, by the way) is in the rear

1. Secure the fuel pump to the bracket (3A) using the two 1/4 BSF setscrews and 1/4" lock washers provided.
2. Put one of the rubber pads (3E) on either side of the bracket.
3. Push the 1/4" x 1" bolts (3G) through flat washers (3F) and through the pads (3E) and the bracket (3A). *You could use the retainer plate (2F) included in the kit for use on the TD-TF instead of the washers. If you have the original AJD7212 washers, you can also clean them up and re-use them if you prefer.*
4. Hold the pump and bracket assembly up to the mounting plate on the vehicle (3H).
5. Push the bolts (3G) through the holes in the mounting plate (3H).
6. Hold the 1/4" Nyloc nuts up behind the mounting plate (3J) and thread the bolts into the nuts.

We have replaced the nut and jam nut originally used on the MGA (see 1D) with a Nyloc nut.

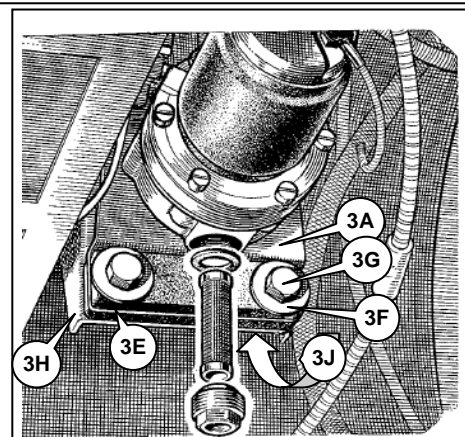
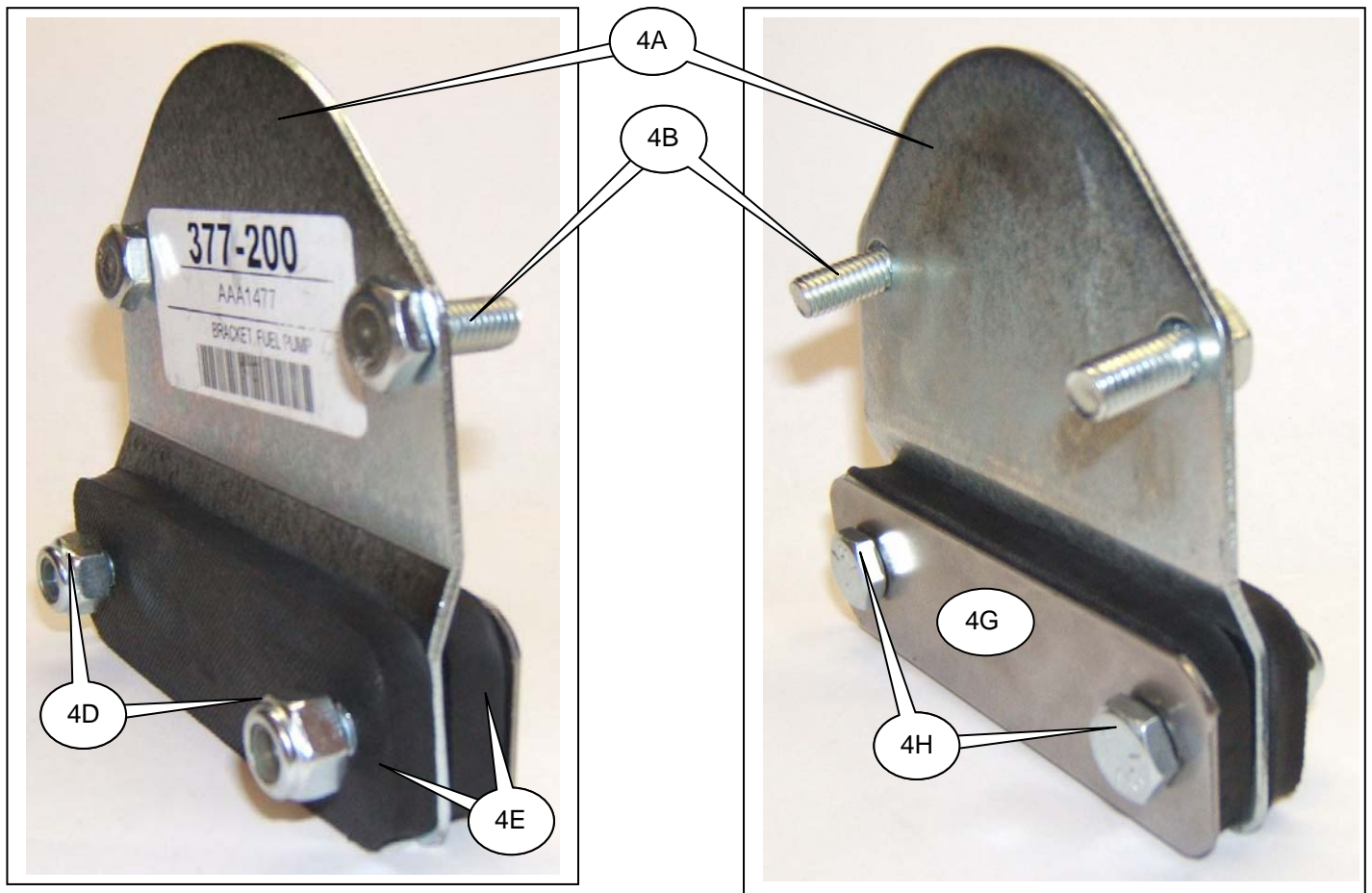

Fig 3 MGA from workshop manual



Ref	Item #	Description	Qty
4A	377-200	Bracket, fuel pump mount	1
4B	320-180	Setscrew, 1/4 BSF X 5/8, for pump	2
4C	324-855	Lock Washer, 1/4, for setscrews	2
4D	310-100	Nut, Nyloc, 1/4 UNF, thin	2
4E	280-230	Rubber Pad, for fuel pump bracket	2
4F	324-590	Flat Washer, 1/4 IN, for MGA	2
4G	377-220	Retainer Plate, over rubber pad, for MGT	1
4H	322-247	Bolt, 1/4 UNF X 1, bracket to chassis	2

Although every effort has been made to ensure the accuracy and clarity of this information, errors and/or omissions on our part are almost inevitable. Any suggestions that you may have that will improve the information (especially detailed installation notes) are welcome. Please use the simple email form on the "Contact Us" page on the Moss website: <http://www.mossmotors.com/AboutMoss/ContactUs.aspx>
If you prefer, you may call our Technical Services Department at 805-681-3411. So many people call us for help that we are often not able to answer the calls as fast as we'd like, and you may be asked to leave a message. We apologize in advance for the inconvenience. We will get back to you within 2 business days.



Moss Motors, Ltd.

440 Rutherford Street, Goleta, California 93117
In the US & Canada Toll Free (800) 667-7872 FAX (805) 692-2510 (805) 681-3400

Moss Europe Ltd.

Hampton Farm Industrial Estate, Hampton Road West, Hanworth Middlesex, TW13 6DB
In the UK: 020-8867-2020 FAX:- 020-8867-2030