

VP00414-1

mazda



BRITISH MOTOR
HERITAGE APPROVED



Vitesse

**VITTR253 - Triumph TR5-6
Gearbox Conversion Kit**

Ver. 1

Fitting Instructions



KIT CONTENTS

- Mazda MX-5 5 Speed Transmission:
 - Vitesse Gearbox Case
 - Vitesse Bellhousing
 - Vitesse Machined Front Plate
 - Modified rear case with shortened remote housing
 - Mechanical or electronic speedo drive
- Bespoke Clutch Friction Plate
- Clutch Cover
- Vitesse Bespoke Shift Lever and Gear Knob
- Concentric Slave Cylinder Assembly with feed and bleed pipes
- Prop Shaft
- Spigot Bush
- Speedo Drive Cable with Angle Drive
- Gearbox Rear Mount Bracket Assembly and Isolator
- Dash Support Bracket Finisher and Spacers
- Dash Support Bracket Adapter Plates
- Clutch Alignment Tool
- All required fixings- see next page

FIXINGS

- The gearbox, bellhousing, concentric slave cylinder assembly and speedo drive are all pre-assembled, ensuring that the installation to your vehicle is as straightforward as possible.

VP00381-1 - TR BELLHOUSING BOLT KIT 2 TR5-6		
Product Code	Description	Quantity
VF002-1	M8 FORM A WASHER ZINC (1.5mm)	13
VF012-1	5/16" UNF PLAIN NUT ZINC	13
VF013-1	5/16" SPRING WASHER ZINC	13
VF021-1	3/8" SPRING WASHER ZINC	4
VF041-1	5/16" UNF x 1 3/4" STUD ZINC	3
VF042-1	5/16" UNF x 1 3/8" HEX HEAD BOLT ZINC	10
VF043-1	3/8" UNF PLAIN NUT ZINC	4
VF044-1	3/8" UNF x 1 7/8" BOLT ZINC	2
VF045-1	3/8" SHAKEPROOF WASHER ZINC	2
VF053-1	132872 3/8" UNF DOWEL BOLT	2
VP00379-1 - TR DASH BRACKET BOLT KIT - TR4A-6		
VF002-1	M8 FORM A WASHER ZINC (1.5mm)	4
VF046-1	1/4" UNF x 1" CSK SOCKET SCREW ZINC	4
VF047-1	1/4" UNF x 1/2" HEX HEAD BOLT ZINC	4
VF048-1	1/4" UNF x WASHER ZINC	4
VF049-1	5/16" UNF x 1 7/8" HEX HEAD SCREW ZINC	2
VF050-1	5/16" UNF x NYLOC NUT ZINC	2
VP00382-1 - TR REAR MOUNT BOLT KIT TR4A-6		
VF002-1	M8 FORM A WASHER ZINC (1.5mm)	8
VF004-1	M10 FORM A WASHER ZINC	8
VF012-1	5/16" UNF PLAIN NUT ZINC	4
VF023-1	M6x1x12 DOMED SCREW ZINC	3
VF043-1	3/8" UNF PLAIN NUT ZINC	4
VF051-1	5/16" UNF x 3/4" SET SCREW ZINC	4
VF052-1	3/8" UNF X 1 1/4" SET SCREW ZINC	4

VEHICLE AND WORKSHOP PREPARATION

- Ensure you have a clean, safe working environment with enough room around your vehicle.
- We strongly recommend the use of a vehicle lift and an engine hoist with a ratchet winch, so the angle of inclination can be adjusted when removing / refitting the engine and gearbox assembly.
- Use a torque wrench to ensure all fixings are torqued correctly.
- Ensure clutch cable is in the correct orientation for the hand of drive of vehicle.
 - Hold the cable upright over the gearbox.
 - The banjo eyelet should point to the DRIVER'S SIDE FRONT WHEEL if the gearbox were to be installed in the vehicle:
 - For RHD vehicles the banjo eyelet should point to the right front wheel
 - For LHD vehicles the banjo eyelet should point to the left front wheel
- A small modification is required to allow this gearbox kit to be fitted- the enlarging of the tunnel aperture. Refer to the relevant section for details of the modification.
- **NOTE:**

The gearbox comes pre-filled with oil, unless the oil has been drained and supplied in bottles (for some international markets). As there is residual oil in the gearbox there is sufficient oil in the bottles to refill to the specified levels. The main case and shift case have separate oil, and should be filled as follows:

OIL GRADE: API Service GL-4 or GL-5

OIL VISCOSITY: SAE 75W-90

OIL CAPACITY: 2.0L {2.1 US qt, 1.8 Imp qt}

SHIFT CONTROL CASE OIL CAPACITY: 290-330ml {17.69—20.13 cu in}

OIL SERVICE INTERVAL: Every 5 years or 62,000 miles (100,000km), whichever comes first

DISASSEMBLY

The installation can be performed through the cabin as per the workshop manual, which allows fitment of the gearbox without disturbing the engine.

1. Drive the vehicle on to a ramp if available, or lift it to a sufficient height to work underneath. Isolate the battery.
2. Remove both seats:
 1. Release the squab catch and tip the seat forward.
 2. Remove the two nuts, bolts and four plain washers.
 3. Disconnect the harness plug.
 4. Remove the seat from the car.

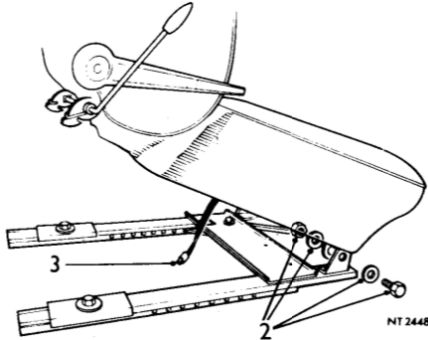

3. Remove transmission side trim panels:
 1. Remove the screw and cup washer securing the front end of the trim pad to the gearbox tunnel cover.
 2. Disengage the rear end of the trim pad from the fascia support bracket. Lift off the trim pad.

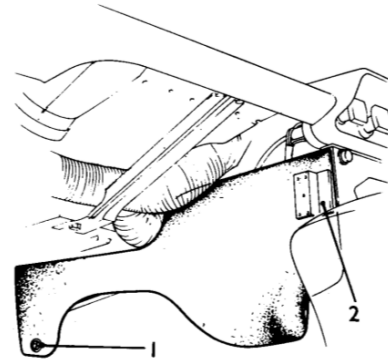

4. Remove the fascia support bracket:
 1. Prise off the caps and remove the two nuts and bolts.
 2. Remove the four bolts and washers securing the bracket to the floor.
 3. Lift off the bracket.

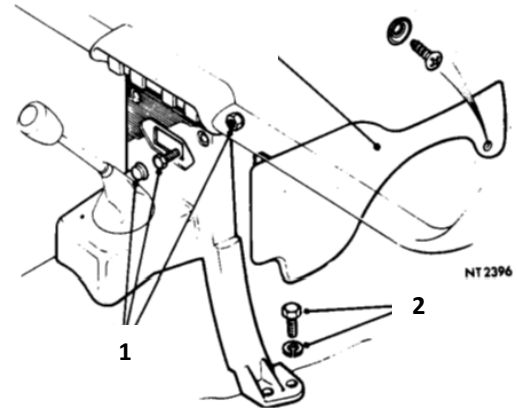

DISASSEMBLY

5. Remove the gear lever:

1. Slacken the locknut and unscrew the gear lever knob.
2. Remove the gear lever grommet.
3. Position gear lever in Neutral.
4. Take out the bolt.
5. Slacken the locknuts
6. Depress and turn the gear lever cap, and withdraw the cap, plate and spring.
7. Withdraw the gear lever.

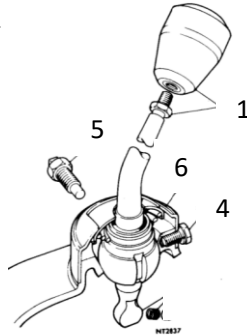

6. Remove the carpet and the transmission cover panel:

1. Remove front & rear tunnel carpets.
2. Disconnect snap connectors (2 on non-overdrive, 5 on overdrive models).
3. Remove the 17 bolts and washers securing the cover to the floor and bulkhead..
4. Break the seal between the cover, floor and bulkhead and manoeuvre the cover over the gearbox.

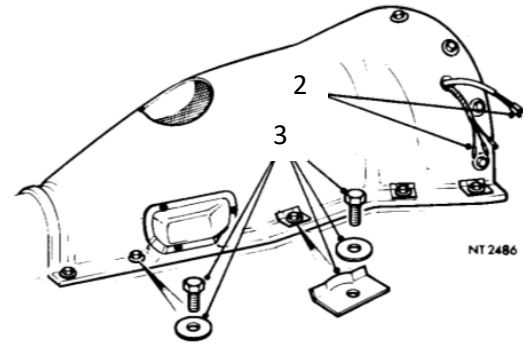

7. Disconnect the prop shaft from the gearbox drive flange.
8. Disconnect the speedometer drive cable from gearbox and gauge.
9. Unscrew and remove the mounting bolts and nuts
10. Remove the exhaust support bracket.
11. Remove the gearbox rear mounting plate bolts.
12. Unscrew the 9 upper engine to bellhousing fixings.

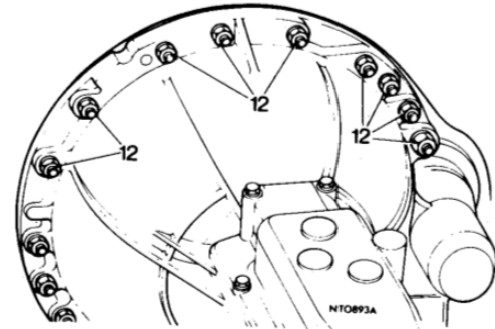

DISASSEMBLY

13. Raise the vehicle.
14. Disconnect the clutch slave cylinder push-rod from the cross-shaft lever.
15. Position a ramp jack under the engine and raise the engine/ gearbox sufficiently to remove the mounting plate assy.
16. Remove the remaining (7) engine to bellhousing fixings.
17. Lower the ramp and lift out the gearbox.

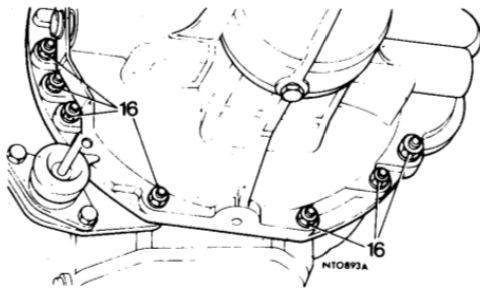

18. Remove clutch cover and clutch disc from flywheel.

CARE POINT: It is highly recommended to inspect the flywheel face condition at this point, and to replace or re-grind if necessary.

VEHICLE MODIFICATION

TRANSMISSION TUNNEL APERTURE

1. The gearbox remote housing shifter turret has been modified to be as far forward as possible, but unfortunately will still clash with the rear edge of the transmission tunnel aperture. A template has been included to show where the tunnel needs to be modified.

ASSEMBLY

The transmission is delivered fully assembled, with the concentric slave cylinder assembly, speedo drive and rear bracket and isolator assembly fitted and ready to be installed to the engine.

1. Fit spigot bush in to flywheel or crank shaft, depending on the vehicle.
2. Fit new clutch cover and disc, using the supplied clutch alignment tool. If fitting a 9.5" clutch (two dowels), then locate one dowel only to the clutch cover and then use the three supplied 5/16" UNC shouldered bolts alternately to correctly align the cover. Torque the 6 bolts in rotation to **20lb/ftft**.
3. Lubricate the gearbox input shaft nose with some copper grease. Lift the gearbox in to the vehicle and align the input shaft with the crank spigot bush. The gearbox should then push up to the engine back face, with a little resistance as you compress the slave cylinder.
4. Fit the upper 9 bellhousing fixings and torque to **20lb/ft (5/16" fixings) or 32lb/ft (3/8" fixings)**.
5. Raise the vehicle and using a ramp jack, lift the engine.
6. Refit the lower 7 engine to bellhousing fixings and torque as above.
7. **CARE POINT:** Attach a socket to the front pulley bolt and turn the engine over, to ensure the assembly is turning freely.
8. For non-overdrive or A-Type Overdrive: Place the rear mount assembly in to position:
 1. Bolt gearbox isolator to the bracket with 2x 5/16" UNF x 3/4" set screws, nuts and washers.



2. Bolt to the chassis brackets using 4x3/8" UNF set screws, nuts and washers.
3. Drill 2 3/8" holes in to chassis rails where the bracket sits and paint to prevent rust.
4. Bolt bracket to the chassis rails with 2x 5/16" UNF x 3/4" set screws, nuts and washers.
5. Torque all fixings to **20lb/ft (5/16" fixings) or 32lb/ft (3/8" fixings)**.

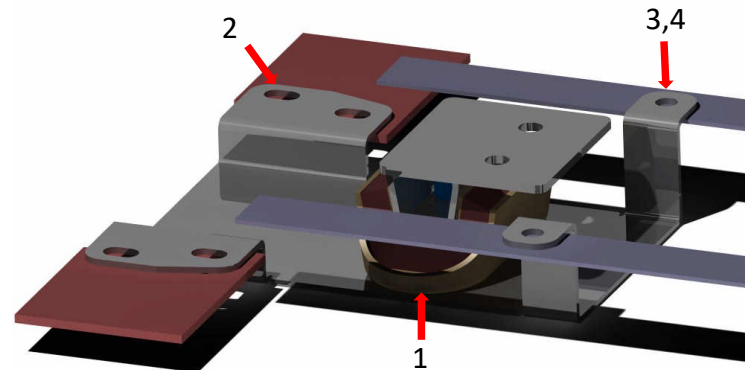

ASSEMBLY

9. For J-type Overdrive:

1. Place the rear mount assembly in to position:
2. Bolt gearbox isolator to the bracket with 2x 5/16" UNF x 3/4" set screws, nuts and washers.
3. Bolt to the chassis brackets using 4x3/8" UNF set screws, nuts and washers.
4. Torque all fixings to **20lb/ft (5/16" fixings) or 32lb/ft (3/8" fixings)**.

10. Refit the exhaust support bracket.

11. Connect the speedo cable and angle drive to the gearbox and route cable up to speedometer.

12. Fit the prop shaft and torque to **34 lb/ft**, using new nyloc nuts.

13. Refit the modified transmission tunnel.

14. Fit the gear lever to the gearbox using 3x M6 dome head screws. Torque to **6lb/ft**.

15. Fit the rubber gasket sheet over the transmission tunnel aperture, around the lower part of the gear lever gaiter and secure with the supplied tape.

16. Bolt the supplied two brackets to the original dash support bracket holes. Secure with 4x 1/4" UNF countersunk screws. Torque to **6lb/ft**.

17. Refit the tunnel carpet as a reverse of removal.

18. Fit gear knob to lever and secure with locknut.

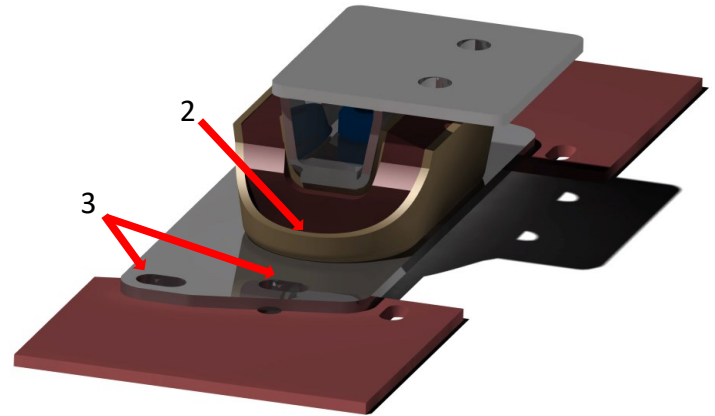

19. Refit the dash support bracket with leather gaiter only:

1. Secure to the brackets on the floor with 4x 1/4" UNF bolts and washers.
2. Secure to dash with the two 25mm spacers and the trim edge hider over the top of the dash support bracket. Use 2x 5/16" UNF x 1 7/8" hex head screws, washers and nyloc nuts. Torque to **20lb/ft**.

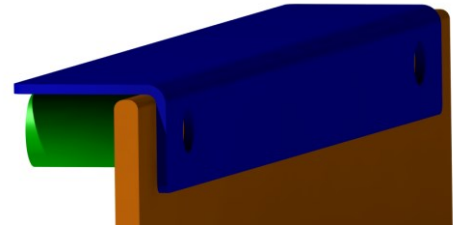

ASSEMBLY

20. Refit the transmission side trim panels as a reverse of removal.
21. Refit both front seats as a reverse of removal.
22. Fit clutch pipe to master cylinder with supplied new banjo bolt and copper washers. Use cable ties to retain pipe.
23. Fill master cylinder with DOT4 brake/ clutch fluid.

24. CLUTCH BLEEDING

Cable tie the bleed pipe to the clutch feed pipe, as it then allows the monitoring of the reservoir fluid level at the same time as controlling the bleed nipple.

- Use an 8mm spanner to undo the bleed pipe ¼ of a turn.
- Depress the clutch pedal fully.
- Tighten bleed pipe.
- Release clutch pedal.

Repeat until resistance is felt through the clutch pedal.

This may take a number of cycles and you must keep an eye on the clutch fluid level in the master cylinder throughout the process to ensure air is not pulled through the system.

SPEEDO CABLE

25. An angled drive is supplied with the kit, which should be fitted to the speedo drive on the gearbox and then the speedo cable is screwed in to it.
26. Connect reverse light switch if reverse lights are fitted. The

fly leads have been fitted with bullet terminals to be compatible with the existing vehicle wiring.. The fly leads can be extended by bending the clip on the gearbox body out of the way to aid fitment.

27. As an optional safety feature, there is a neutral switch that can be connected in line with the ignition switch. If used, this ensures the engine cannot be started unless the vehicle is in neutral. The neutral switch is the one to the rear of the tailhousing.

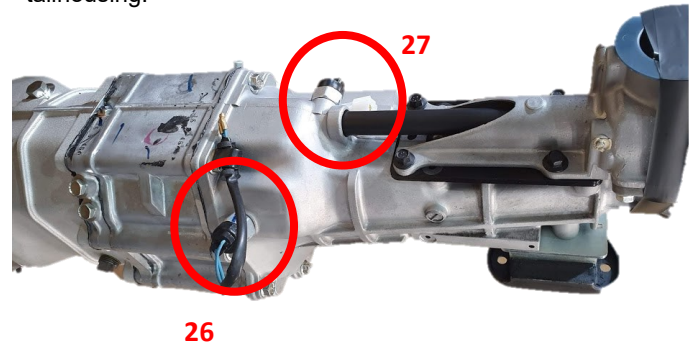

28. Reconnect battery, test drive vehicle and enjoy!

NOTE:

It is likely that the speedometer will need to be re-calibrated to suit the new gearbox. If in the UK, we recommend Speedy Cables (www.speedycables.com) or Speedograph Richfield (www.speedograph-richfield.com) for this work.

VP00370-1

TR TUNNEL CUTOUT TEMPLATE

STANDARD APERTURE

