

## Supplemental Information for 451-060 Badge Bar, 3/4" Diameter MG TD, TF

Fig 1

### About this bar...

Badge bars are among the most common of all the accessories fitted to any British Sports car. We made this bar for the TD & TF to provide a place for your car club badge collection and a place for your driving lights – the second most common accessory for British Sports cars. Normally, the cylindrical spacers (1c,d, 400-100) sit between the end of the frame extensions and the backside of the bumper spring bars. The mounting tabs on the badge bar fit between the bumper spring bars and the cylindrical spacers (1c,d) that ride against the front frame extensions (1a, b).

### But it doesn't fit my car...

From time to time, we will get a call from a TD or TF owner that feels the bar has been made incorrectly because the mounting holes don't line up with the holes in the frame extensions.

It is easy to figure out where the problem lies because the chassis diagram in the factory workshop manual gives the precise center-to-center spacing of the ends of the frame (1a,b) where the bumper and the badge bar attaches.

The relevant section of **Fig S.2** in **Section S.3** of the manual has been reproduced here. (Fig 1) The center-to-center distance between the mounting points is 19 9/16 inches. That is the dimension we specify for the badge bar. The holes in the mounting tabs are also over-sized to allow for any slight variation in the actual distance between the frame horns. Because we have designed our bar with over-sized holes, you actually have some room to work with. If the badge bar we sent does not fit your car, check the distance between the frame extensions as shown above. If it is not the factory specified 19 9/16", that will need to be sorted out before the bar can be mounted, or the mounting holes on the badge bar will need to be enlarged to match your car. If that is done, paint the mounting tabs with a good primer to prevent rust. The ends of the tubes are sealed with rubber plugs, and may be ordered if needed – ask for 2 of 280-285.

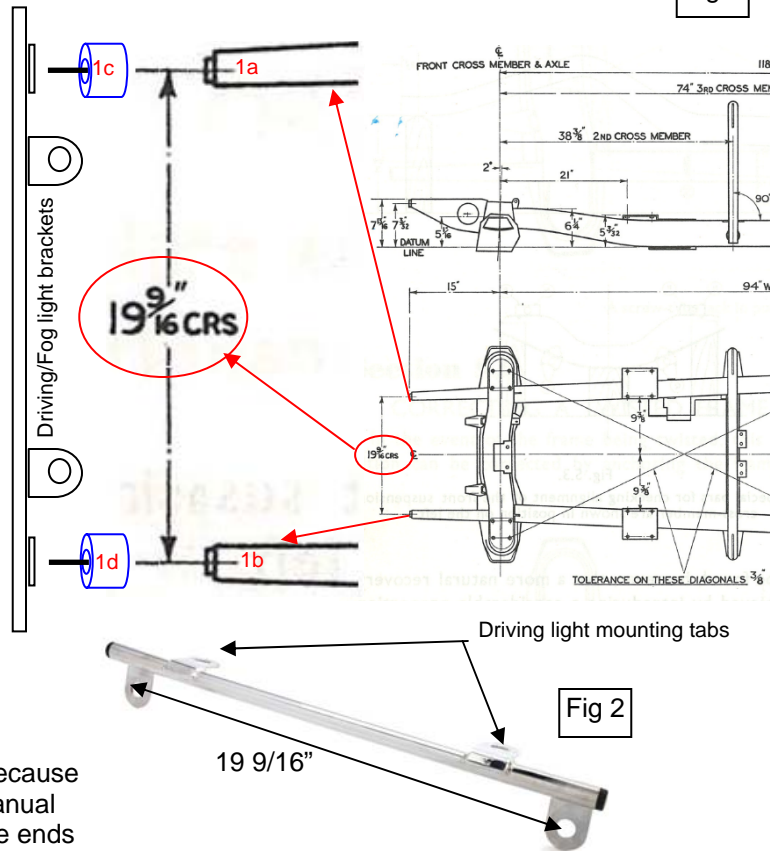

Although every effort has been made to ensure the accuracy and clarity of this information, any suggestions that you may have that will improve the information (especially detailed installation notes) are welcome. Please use the simple email form on the "Contact Us" page on the Moss website: <http://www.mossmotors.com/AboutMoss/ContactUs.aspx>  
If you prefer, you may call our Technical Services Department at 805-681-3411. So many people call us for help that we are often not able to answer the calls as fast as we'd like, and you may be asked to leave a message. We apologize in advance for the inconvenience. We will get back to you within 2 business days.



#### Moss Motors, Ltd.

440 Rutherford Street, Goleta, California 93117  
In the US & Canada Toll Free (800) 667-7872 FAX (805) 692-2510 (805) 681-3400

#### Moss Europe Ltd.

Hampton Farm Industrial Estate, Hampton Road West, Hanworth Middlesex, TW13 6DB  
In the UK: 020-8867-2020 FAX:- 020-8867-2030