

# Installing New Dzus Fasteners in the TR2-3 Hood 802-918

This Task is complicated only by the fact that the parts you buy don't look as though they go together! In fact, it is quite a simple procedure, as we shall see. First, the components viewed in cross section, look like this before and after assembly.

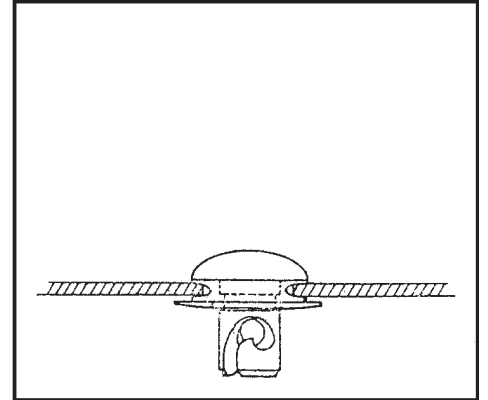
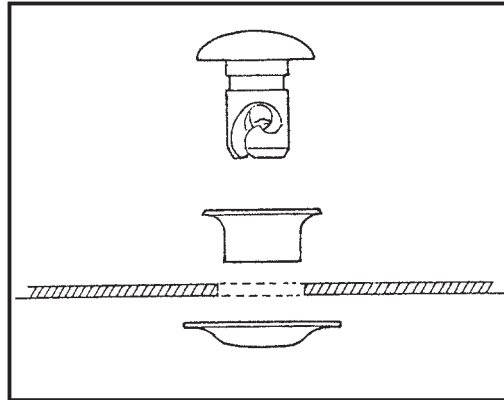
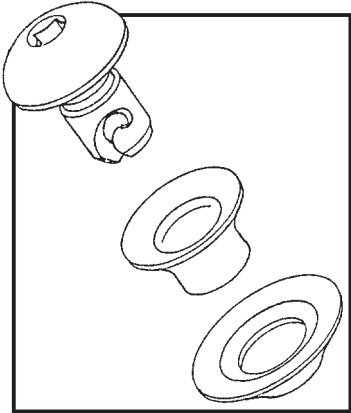

The trick is to flatten the 802-900 Grommet properly, since it must occupy as little space as possible while providing a smooth guide for the fastener itself. There are three steps to the flattening operation, and a helper is required.

## Step 1

Insert the grommet through the hood, flanged end up. Have your helper hold a large ball pein hammer on the top of the grommet to act as a "buck". Hold another, smaller ball pein hammer against the underside of the grommet and strike it with a soft faced hammer to start flaring of the grommet.

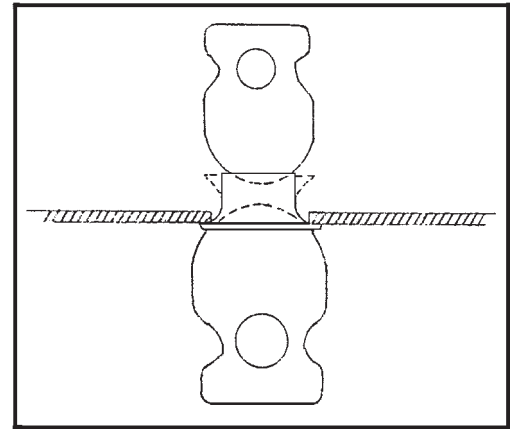

## Step 2

Once to flare is nicely started, complete the flattening of the grommet with a 3/8" diameter bolt, nut, and two flat washers. Draw the nut tight until the grommet is flush to the hood on both sides. (lightly oil the grommet and washers to ease the flattening operation.)

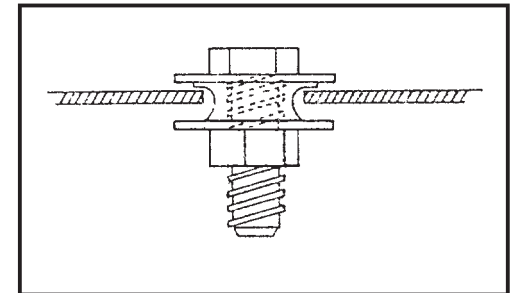

## Step 3

Dress the I.D. of the grommet with a fine rat-tail file. Insert the Dzus fasteners from the top, slip the dished washer over the bottom end of the fastener (dished side up) then flatten the dished part of the washer. This can be done with a piece of metal tubing, a socket wrench or even a punch. After flattening, the washer should be secure in the recessed groove in the Dzus fastener.

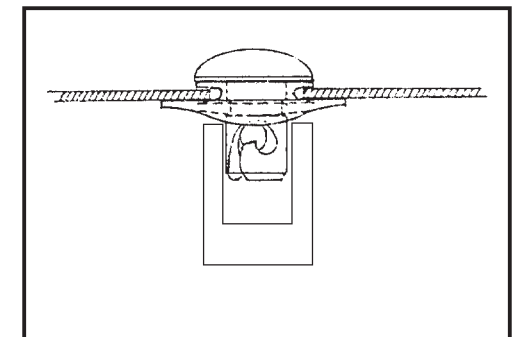

Moss Motors, LTD.

P.O. Box 847

440 Rutherford Street

Goleta, California 93117

(800) 235-6954 Fax (805) 692-2525

Instruction sheet #980-178 10/97

## Triumph Body and Chassis

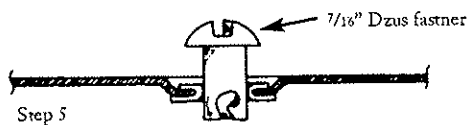
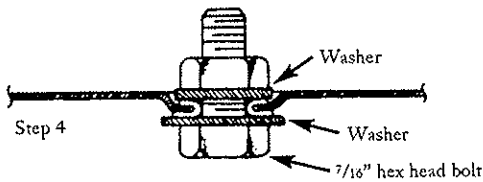
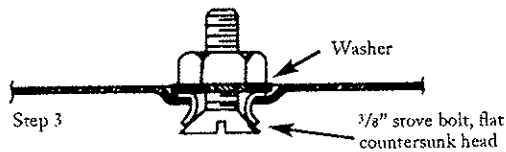
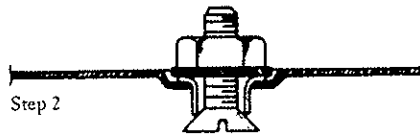
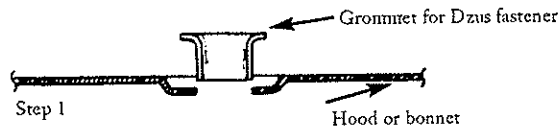

ROSS

### TR3 Dzus Fastener Tip (Alternative)

In order to install the grommet for the Dzus fastener in the hood or bonnet of my Triumph TR3, I successfully used the above-illustrated method that I devised. This method worked beautifully and is far less likely to damage the surrounding paint than other recommended methods that involve using a hammer to flare the grommet. One additional comment though, between steps 4 and 5, a tapered rod, such as a drift pin, may have to be used to enlarge the hole slightly to allow the Dzus fastener to pass through.

William Froehner  
Troy, MI